

\*For more info about compatibility with other models  
please see the sticker on the skid plate

## JEEP WRANGLER JK

**No.:** 2719.1/6 Engine block & gearbox; 2720.1/6 Transfer case plate 1  
2725.1/6 Transfer case plate 2; 2726.1/6 Fuel filter

**Body:** 4 door

**Year:** 2007-

**Engine:** 3.6

**Transmission:** AT

## FITTING KIT

1. Bolt M10x20.....	4 pc
2. Bolt M10x25.....	5 pc
3. Bolt M10x30.....	5 pc
4. Bolt M10x40.....	1 pc
5. Bolt M10x50.....	2 pc
6. Washer 10.....	17 pc
7. Insert nut M10x65/15.....	4 pc
8. Insert nut M10x100/50.....	1 pc
9. Bushing h=22mm.....	2 pc
10. Left bracket.....	1 pc
11. Right bracket.....	1 pc
12. Bracket.....	1 pc
13. Beam 1.....	1 pc
14. Beam 2.....	1 pc

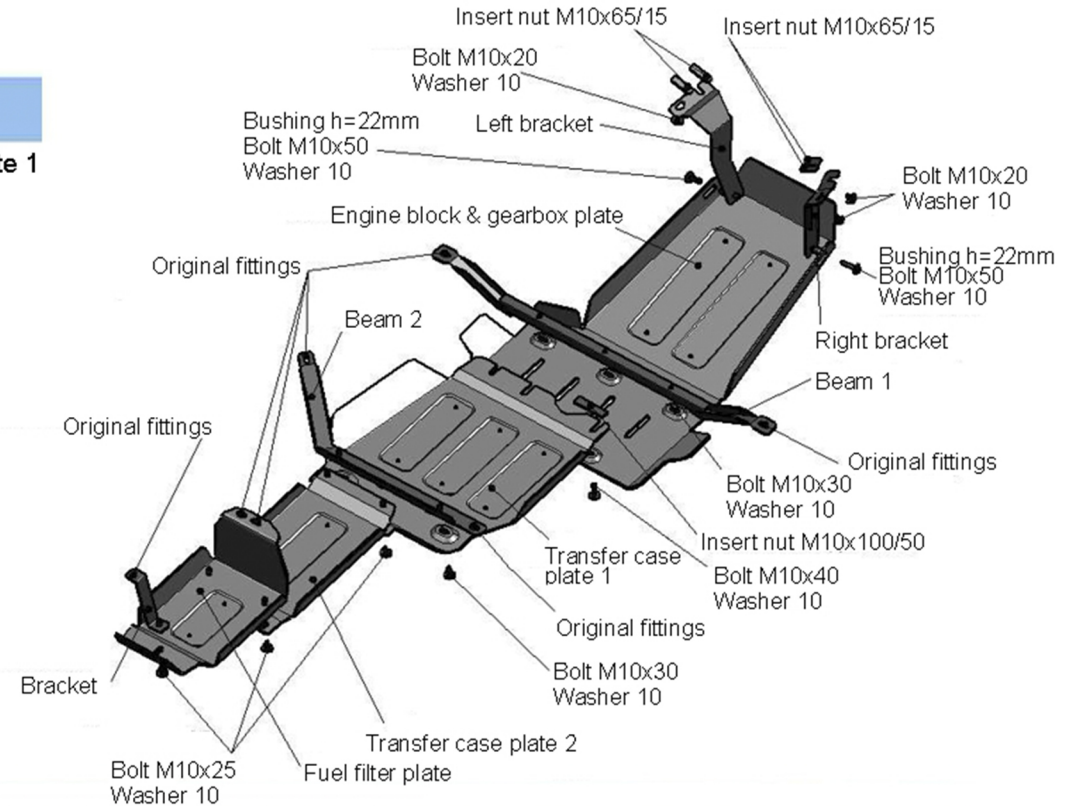

## INSTALLATION INSTRUCTIONS

1. Remove original plastic cover from transfer case and remove original cross-beam.
2. Mount left and right brackets to the beam of underframe with insert nuts M10x65/15 and bolts M10x20.
3. Mount beam 1 to original threaded apertures of underframe with original fittings.
4. Mount beam 2 to original threaded apertures of underframe with original fittings.
5. Place insert nut M10x100/50 above the aperture in the underframe.
6. Screw original bolts out of fuel filter, then mount fuel filter plate to original threaded apertures with the bracket and original fittings.
7. Fix engine block & gearbox plate to left and right brackets with with bolts M10x50 through bushings h=20mm. Then fix the plate to beam 1 with bolts M10x30. After that fix it to mounted insert nut with bolts M10x30.
8. Place front end of transfer case plate 1 under the engine block & gearbox plate. Fix its rear end to beam 2 with bolts M10x30.
9. Connect transfer case plate 1 and fuel filter plate with transfer case plate 2 and bolts M10x25.
10. Tighten all screws (50 Nm for M10, 30 Nm for M8, 10 Nm for M6). Use of pneumatic tools is prohibited.