

EN	UNDERBODY ARMOUR INSTALLATION MANUAL (RADIATOR, ENGINE BAY, GEARBOX, TRANSFER CASE)
DE	MONTAGEEINLEITUNG FÜR UNTERBODENSCHUTZSYSTEM (RADIATOR-, MOTOR-, GETRIEBE-, DIFFERENZIALSCHUTZ)
RU	ИНСТРУКЦИЯ ПО УСТАНОВКЕ КОМПЛЕКТА ЗАЩИТ (РАДИАТОР, КАРТЕР, КПП, РК)



**Underbody Armour for:
Nissan Navara D40 (2005-2015);
Nissan Navara D23 (2015-)**

2333.4164.1;	2333.4165.1;	2333.4166.1;	2333.4167.1;
2333.4164.1/6;	2333.4165.1/6;	2333.4166.1/6;	2333.4167.1/6;
2111.4164.1/3;	2111.4165.1/3;	2111.4166.1/3;	2111.4167.1/3;



РАСПОЛОЖЕНИЕ
LOCATION/POSITION ARROW
ANORDNUNG/
POSITIONSRICHTUNG



ДВИЖЕНИЕ
MOVEMENT ARROW
BEWEGUNGSRICHTUNG



ПОВОРОТ
SCREW ARROW
DREHUNGSRICHTUNG

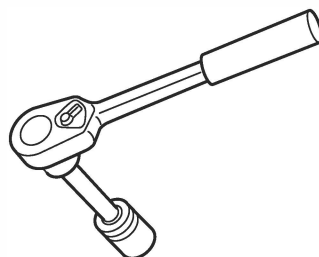
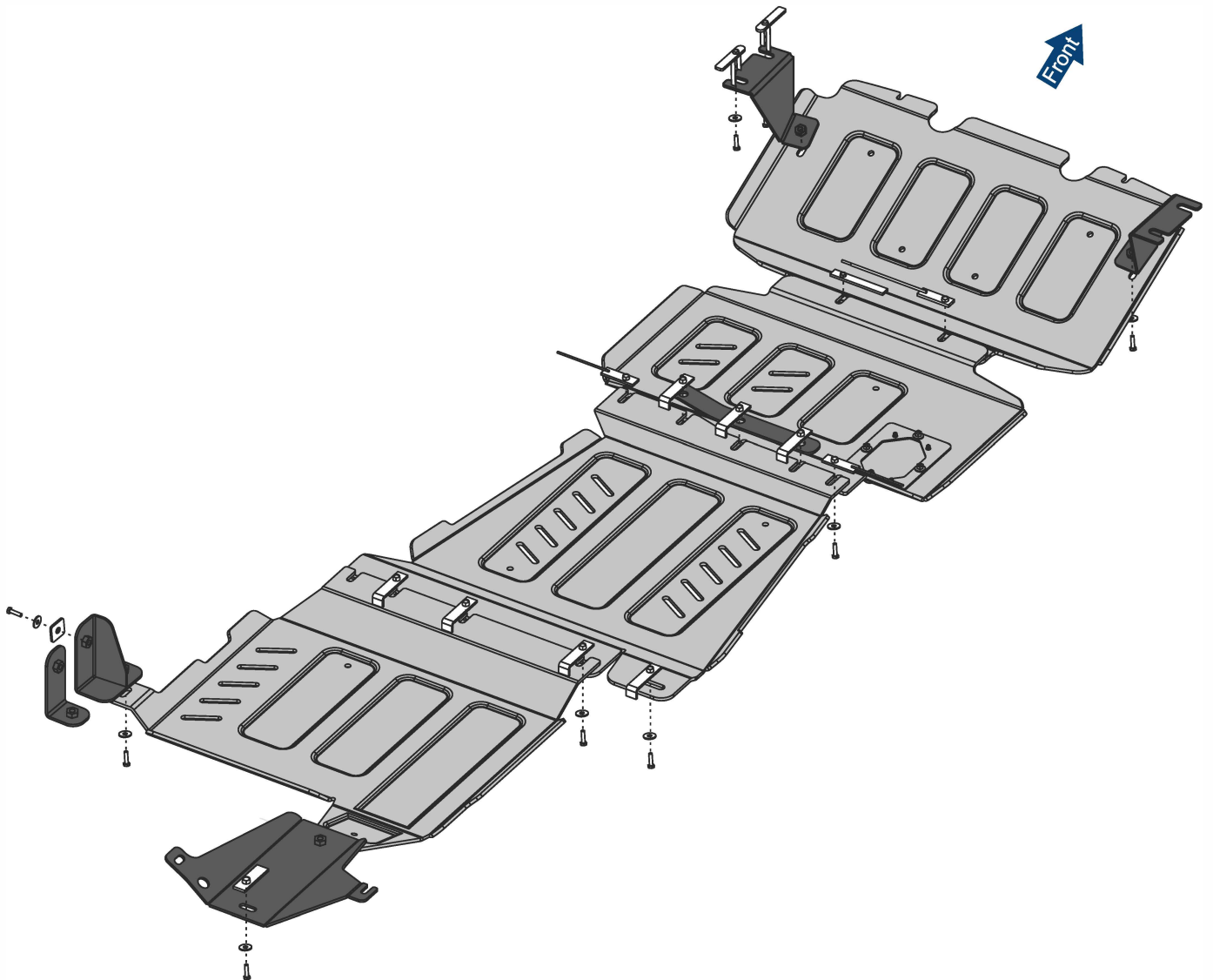

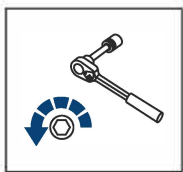

RU Штатный крепеж
GB Regular fasteners
DE Originale montageteile



RU Штатный крепеж
GB Regular fasteners
DE Originale montageteile



RU Вкрутить на несколько оборотов
GB Screw a several turns
DE Für wenigen Umdrehungen befestigen

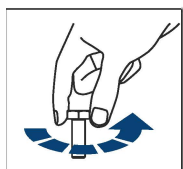

RU Выкрутить на несколько оборотов
GB Loosen bolts
DE Bolzen lockern

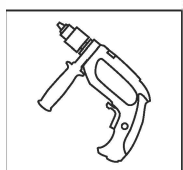

RU Дрель
GB Drill
DE Bohrer

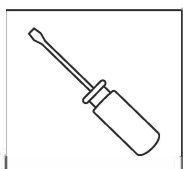

RU Отвертка
GB Screwdriver
DE Schraubenzieher

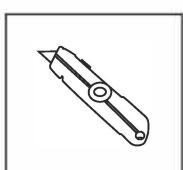

RU Канцелярский нож
GB Office Knife
DE Büromesser

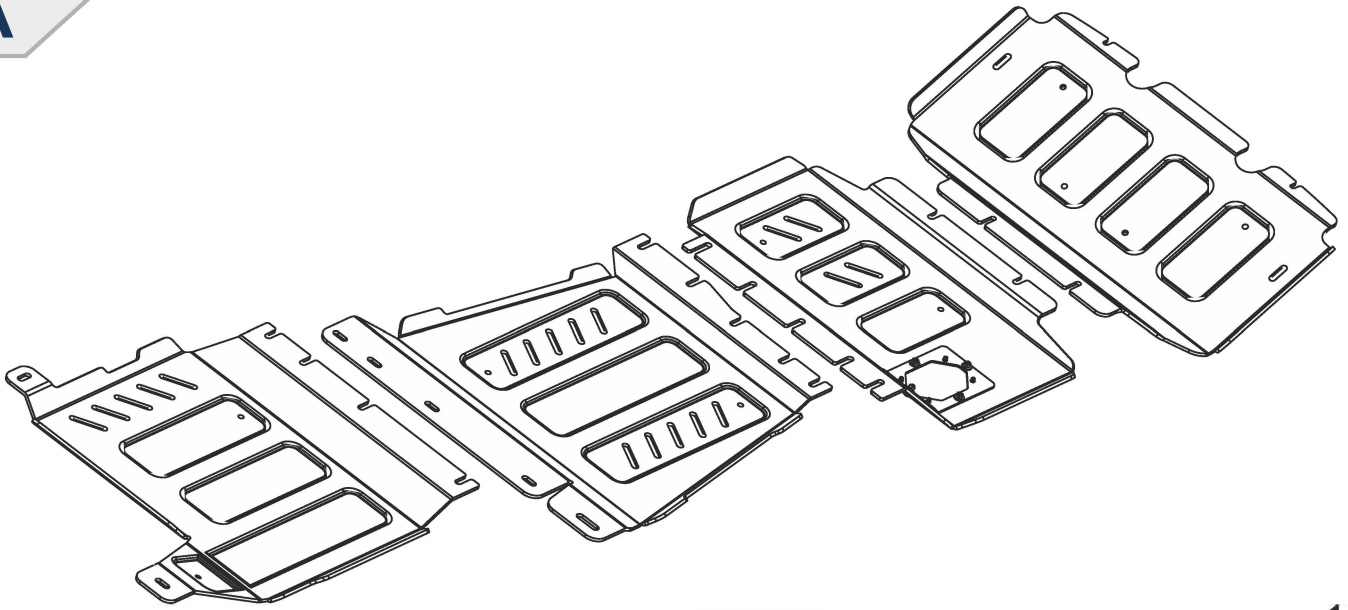
A

1x

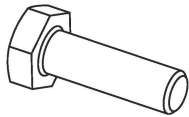
B

M8x35

4x

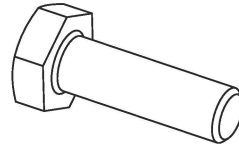
C

M10x30

5x

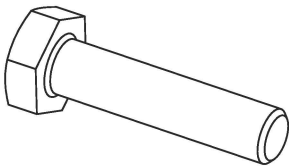
D

M10x40

2x

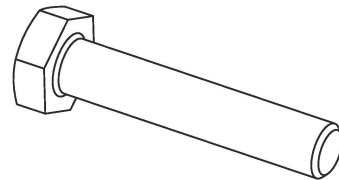
E

M10x60

5x

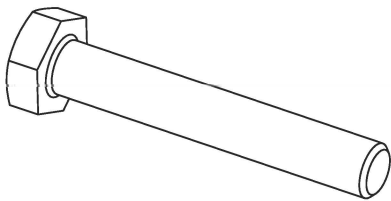
F

M10x80

3x

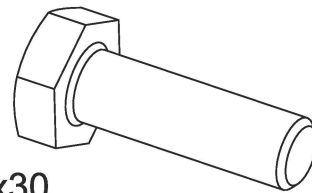
G

M12-1,25x30

2x

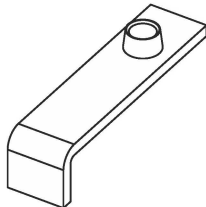
H

M10x80

7x

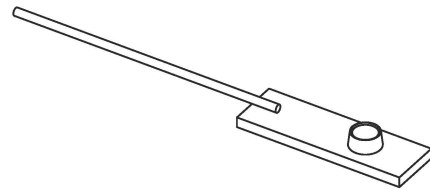
I

M10

2x

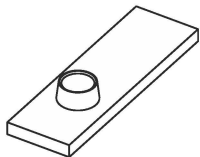
J

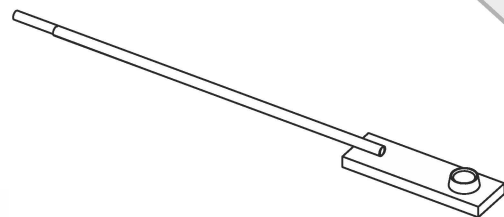

M10x65/20

1x

K

M8

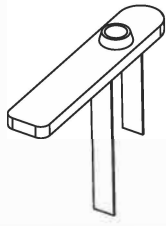
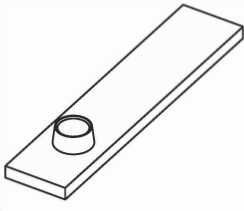
1x

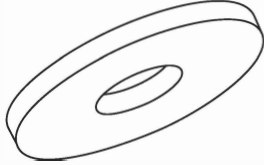
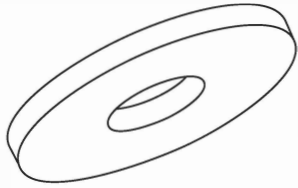
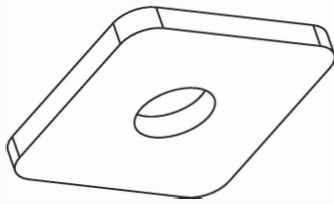
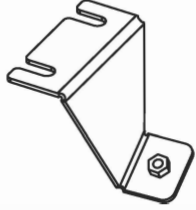
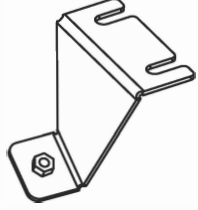
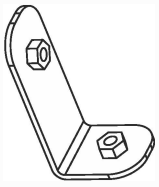
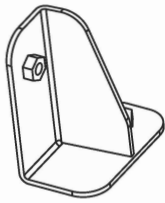
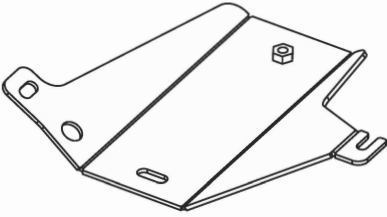
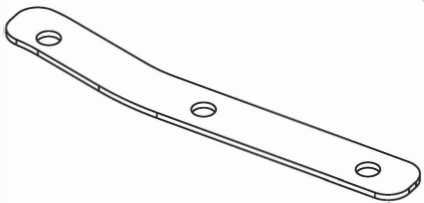
L			M
M8x70/20	2x	M8x100/20	1x
N			O
∅ 8	4x	∅ 10	15x
P			Q
∅ 12	2x	∅ 10	1x
R			S
	1x		1x
T			U
	1x		1x
V			W
	1x		1x

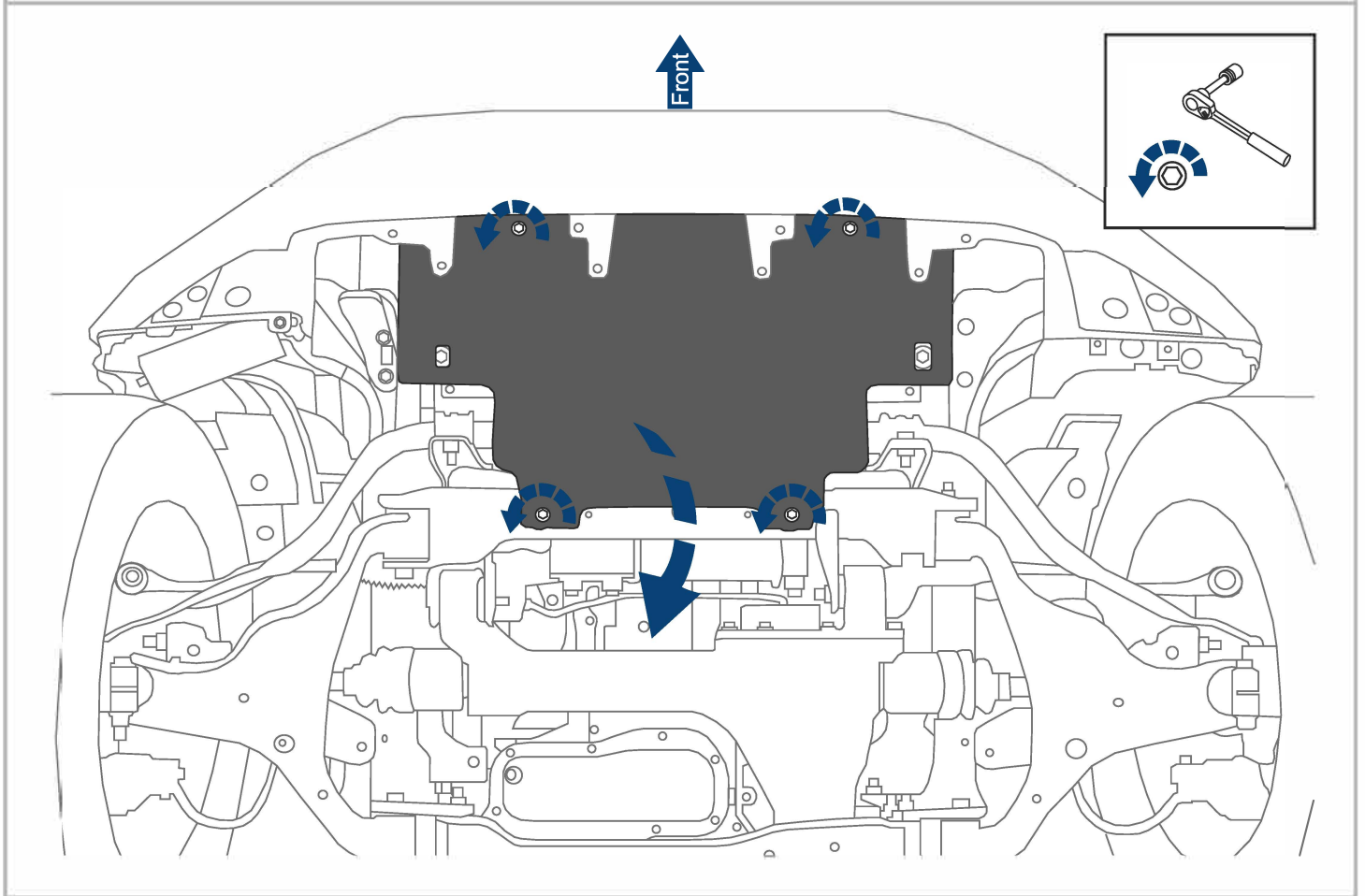
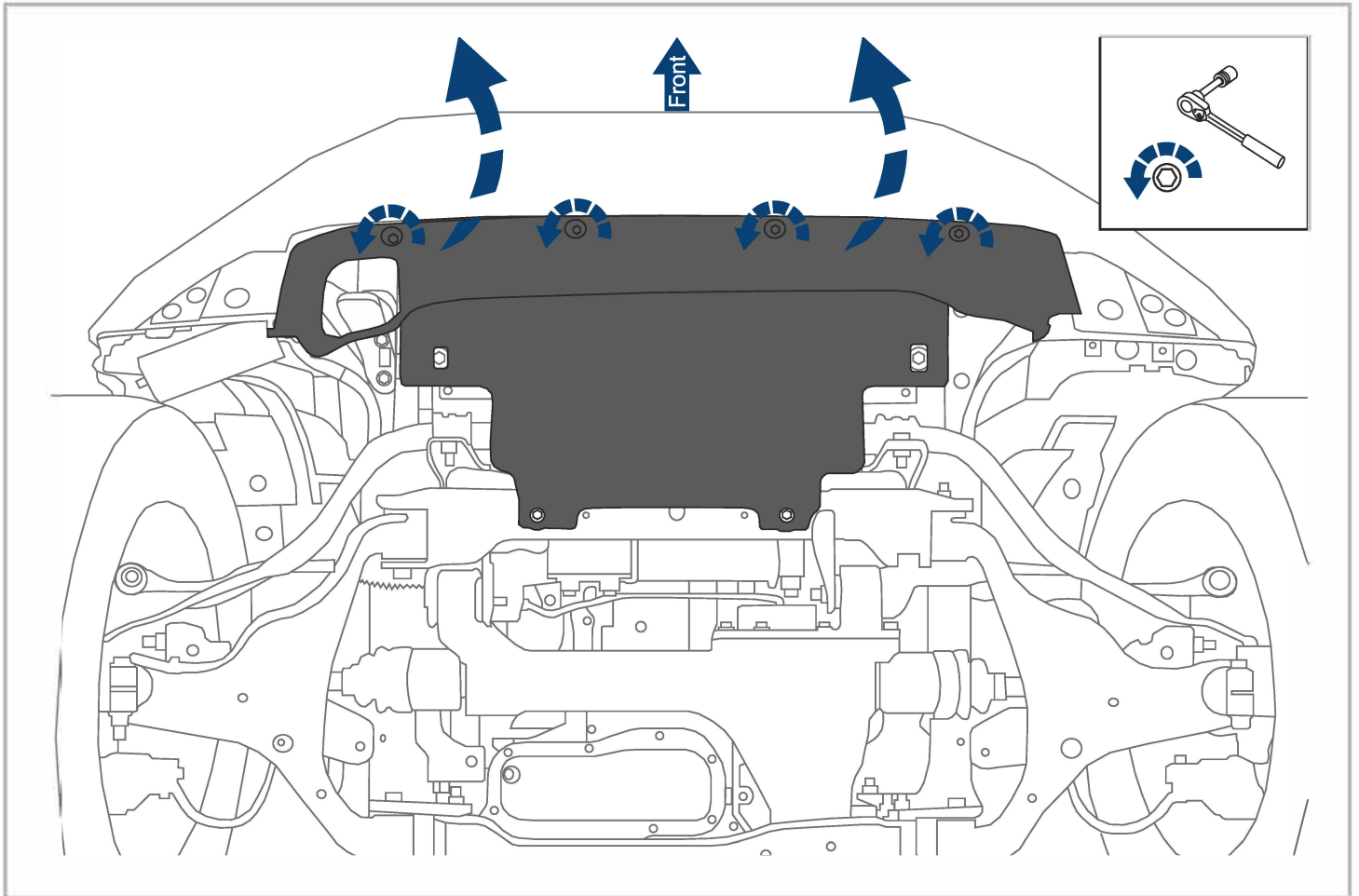

Navara D40

Front ↑

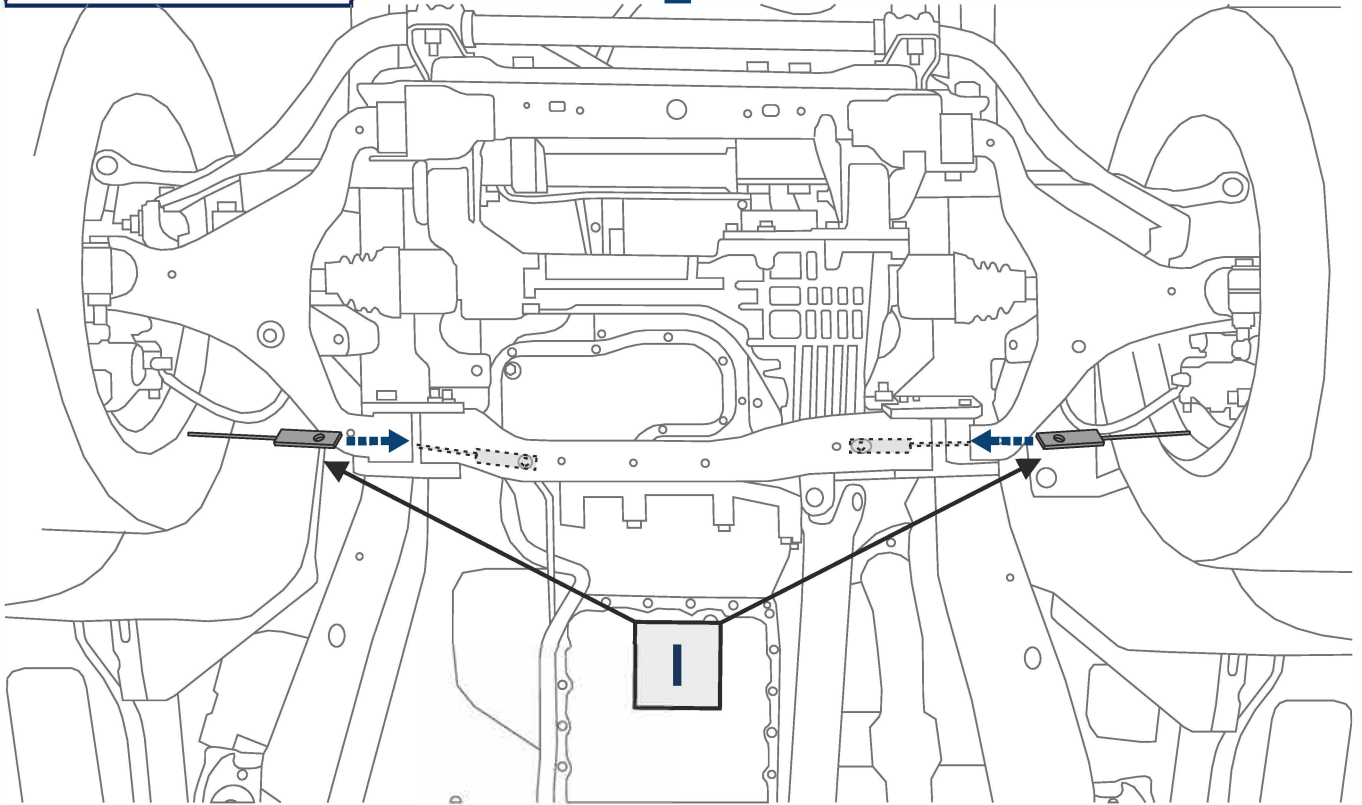

Navara D23/D40

Front ↑

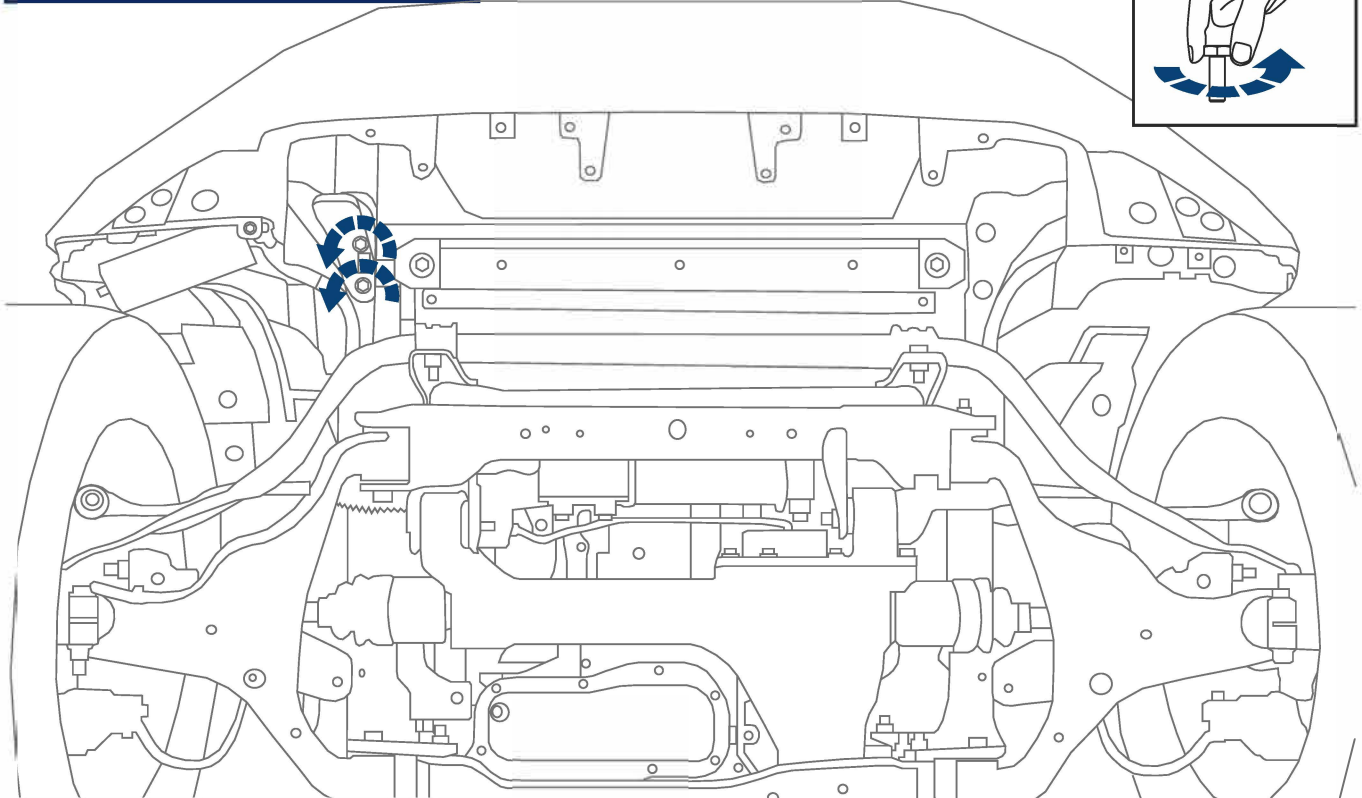
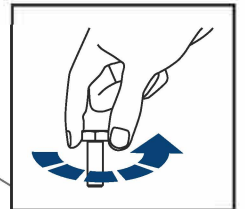

Navara D23/D40

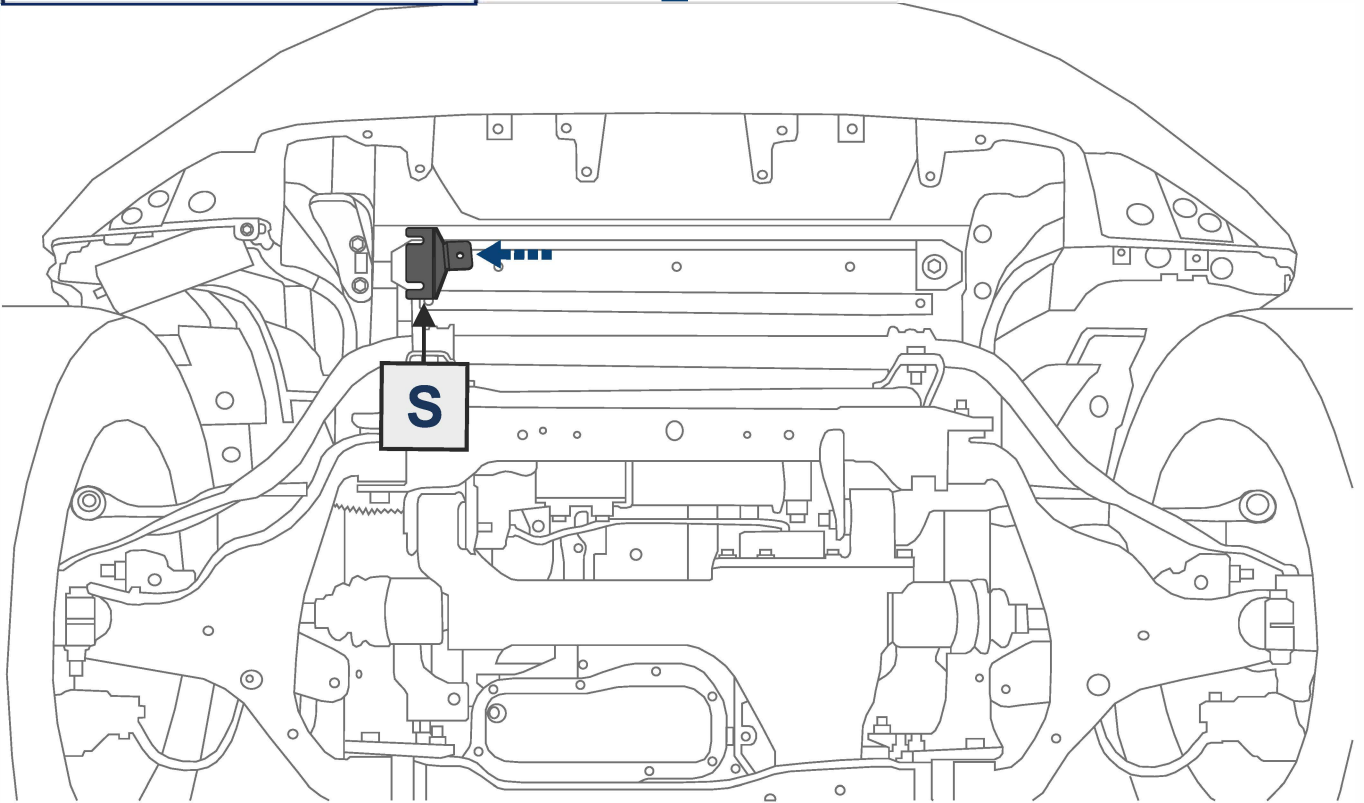

Navara D23/D40

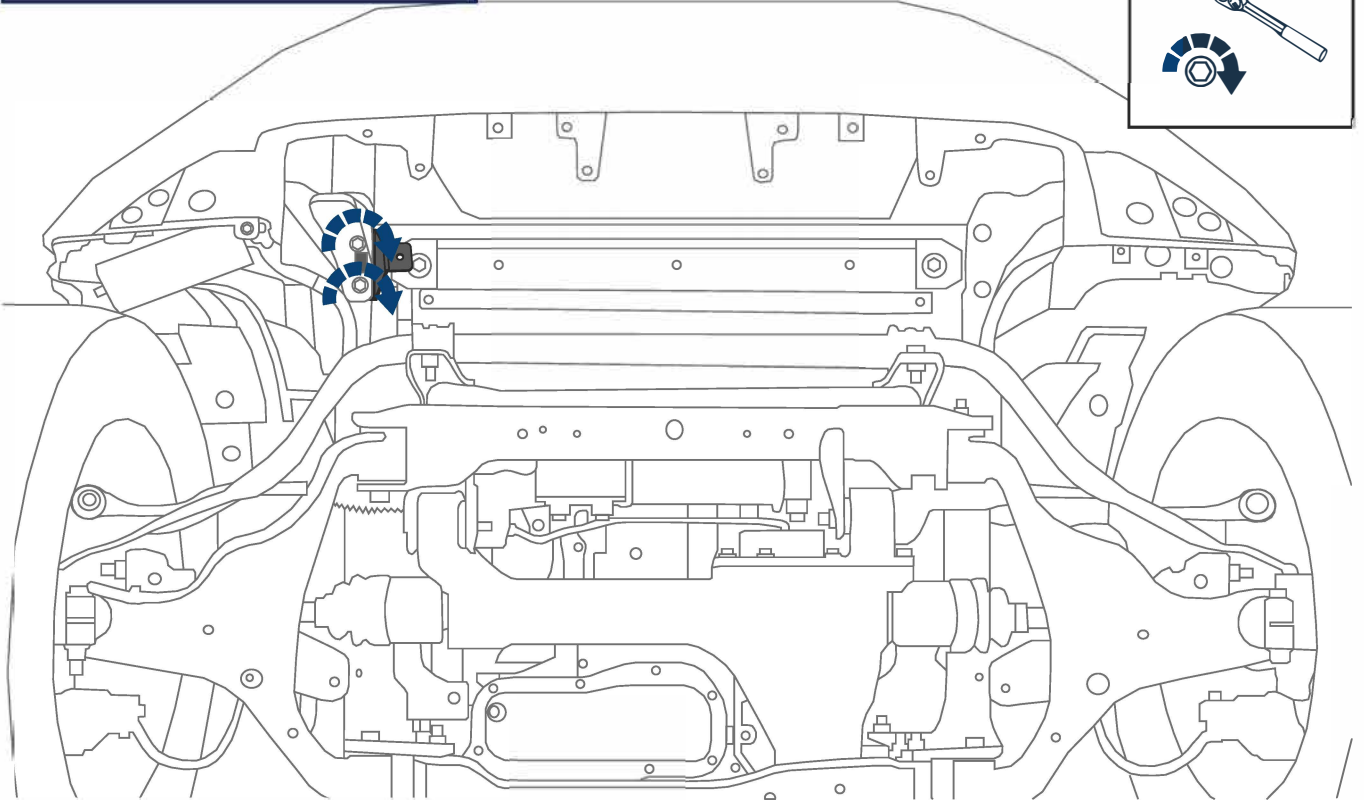

Navara D23

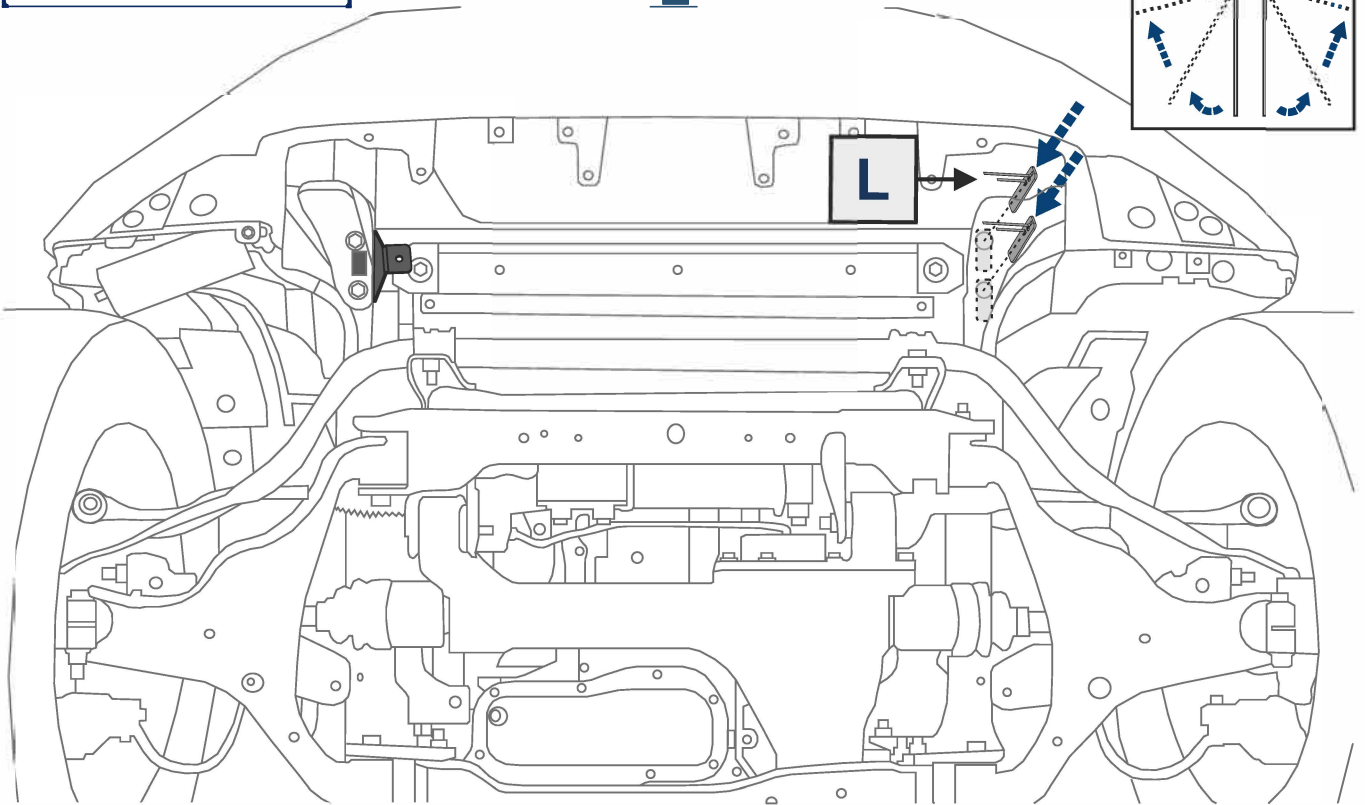
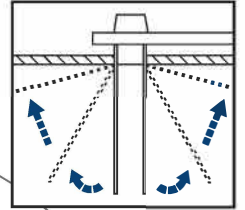

Navara D23

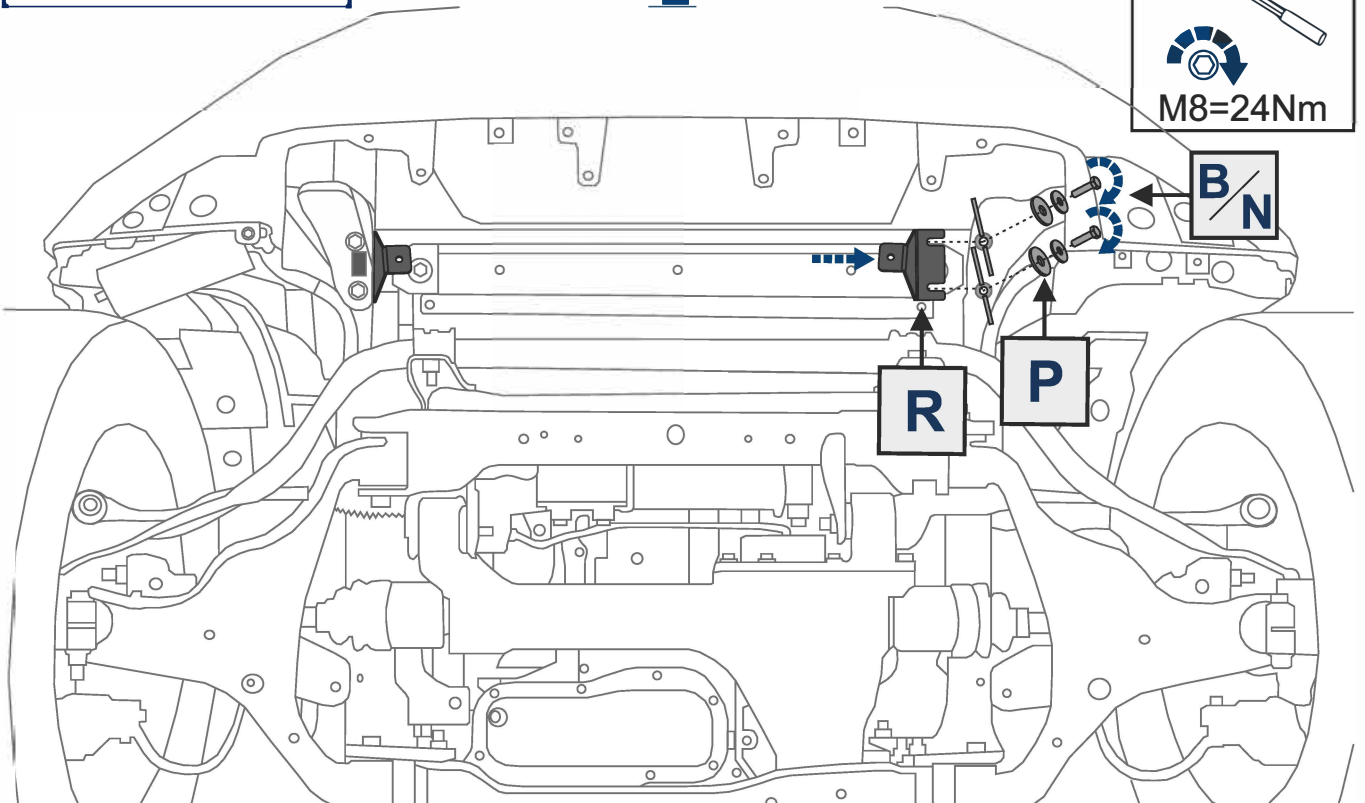

Navara D40

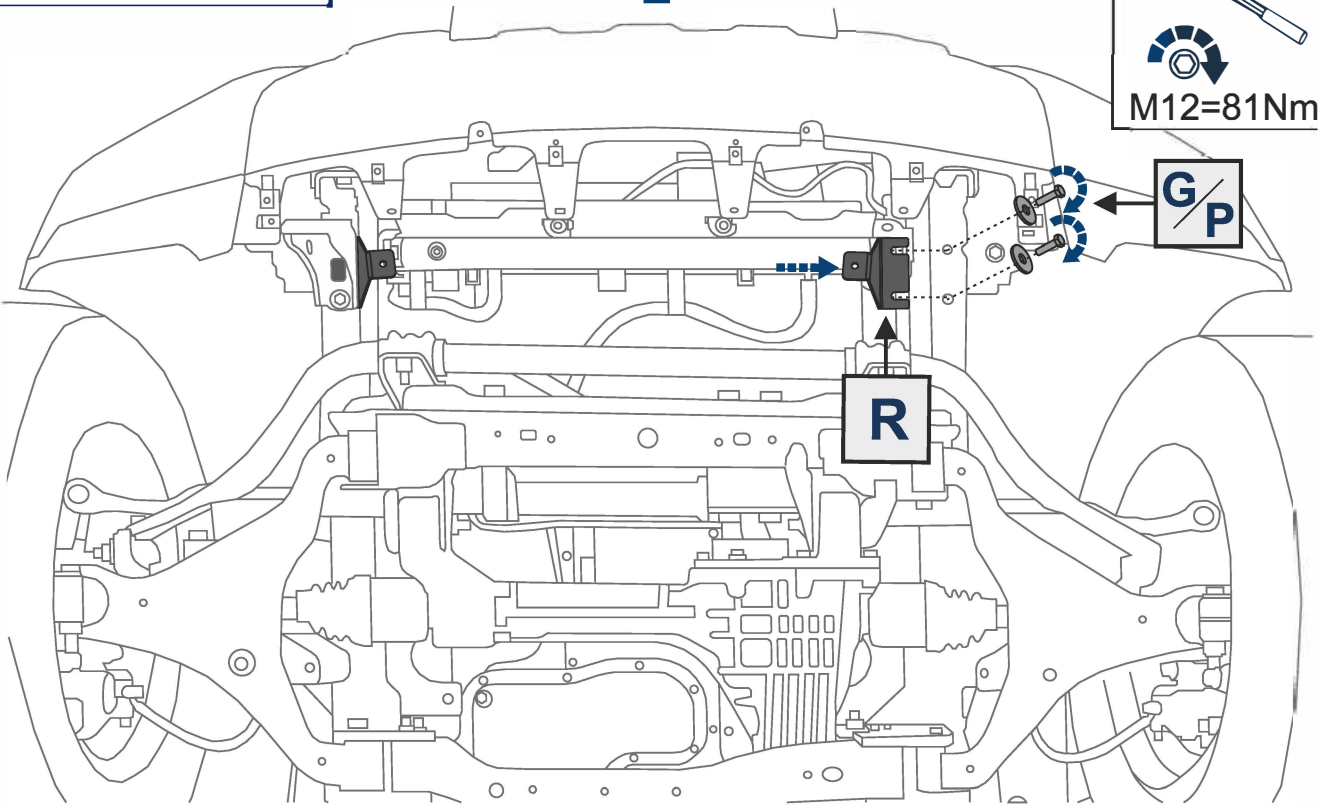

Navara D23

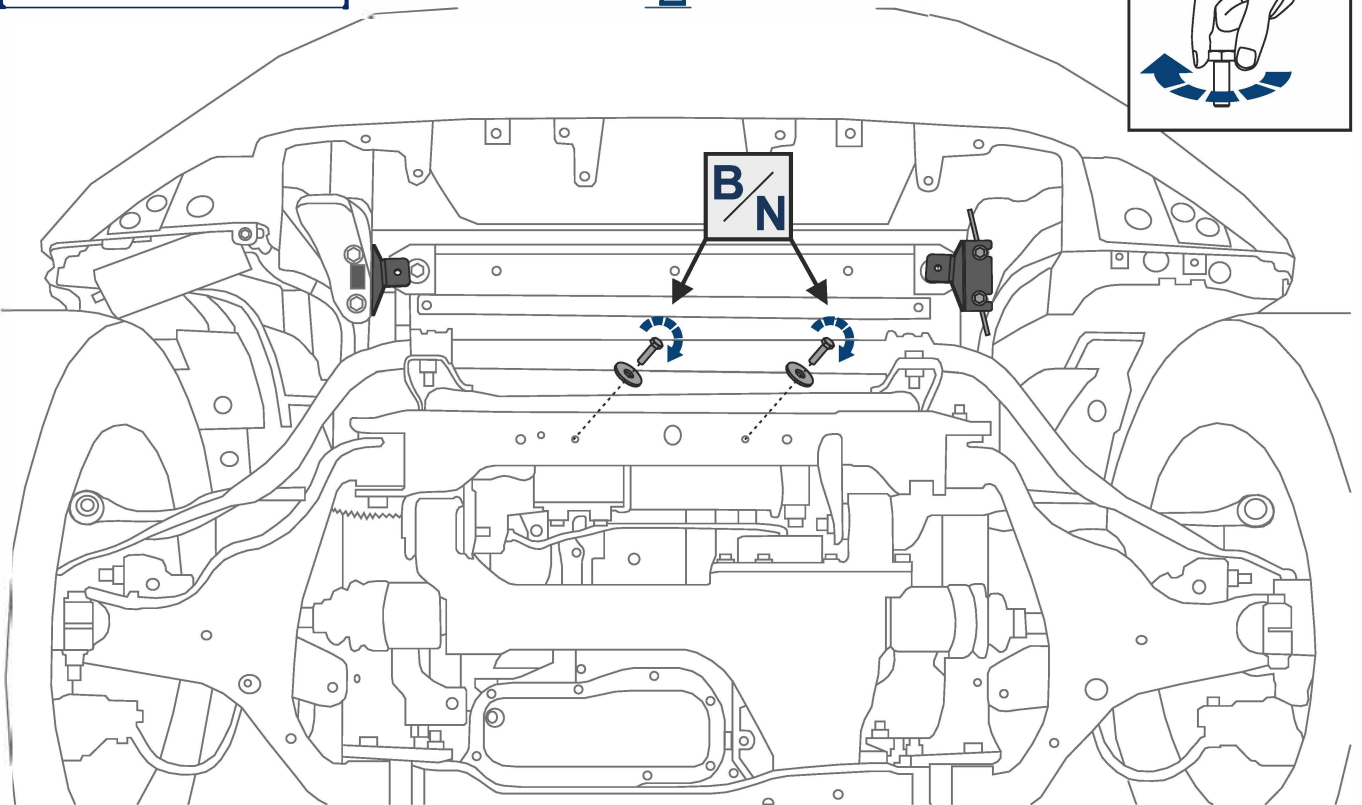
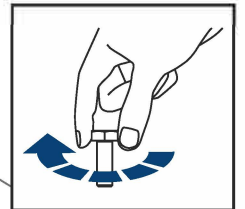

Navara D40

Front ↑

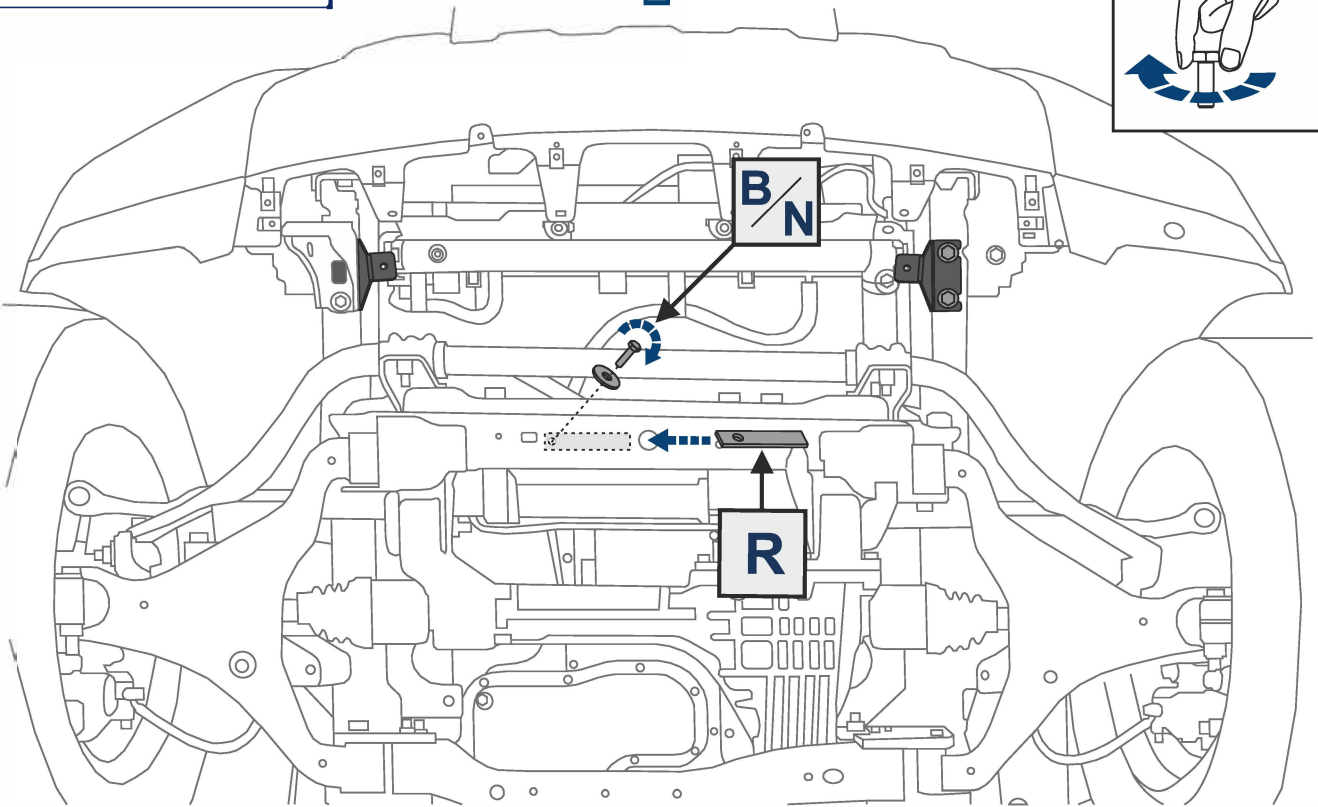
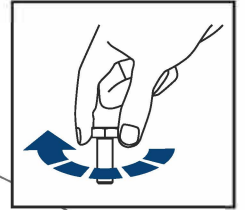

Navara D40

Front ↑

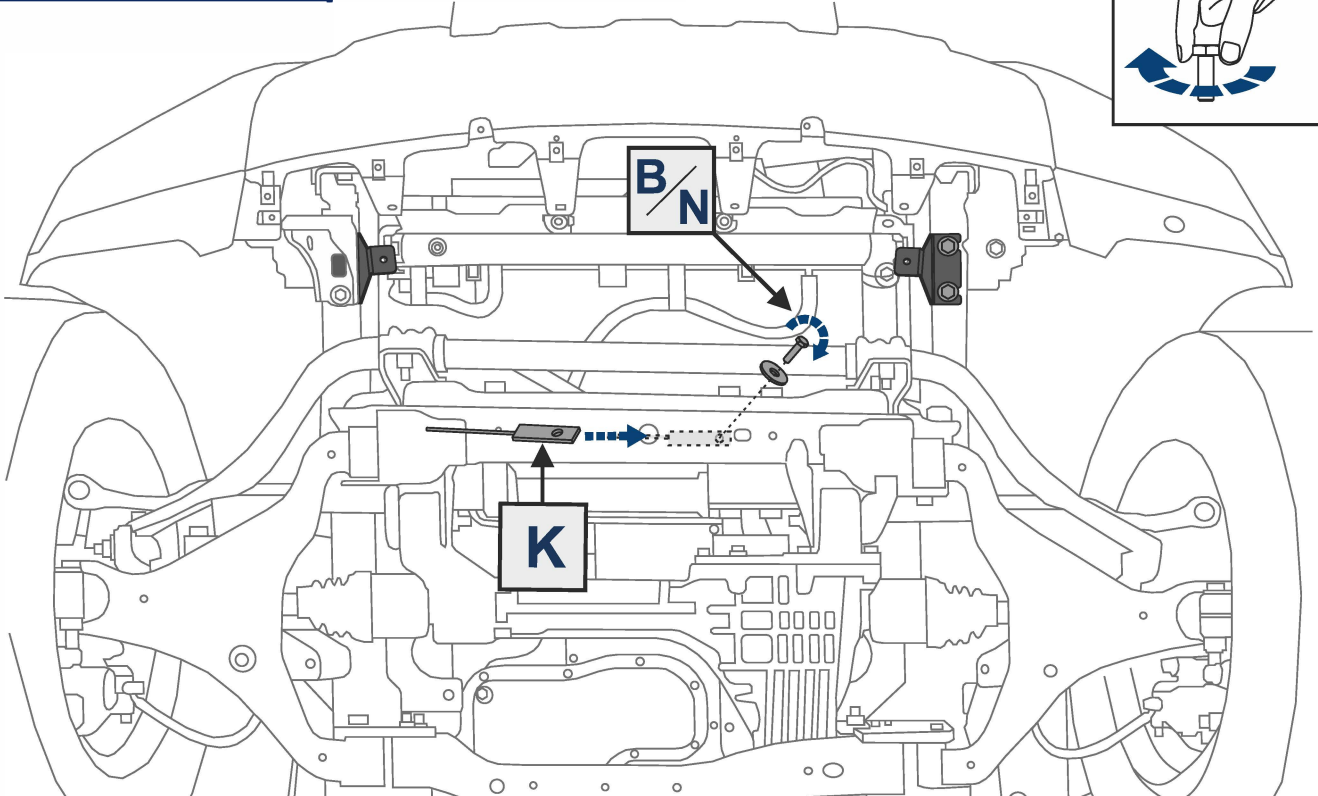
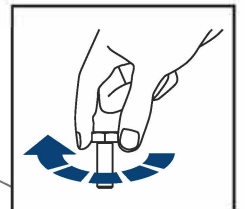

Navara D23/D40

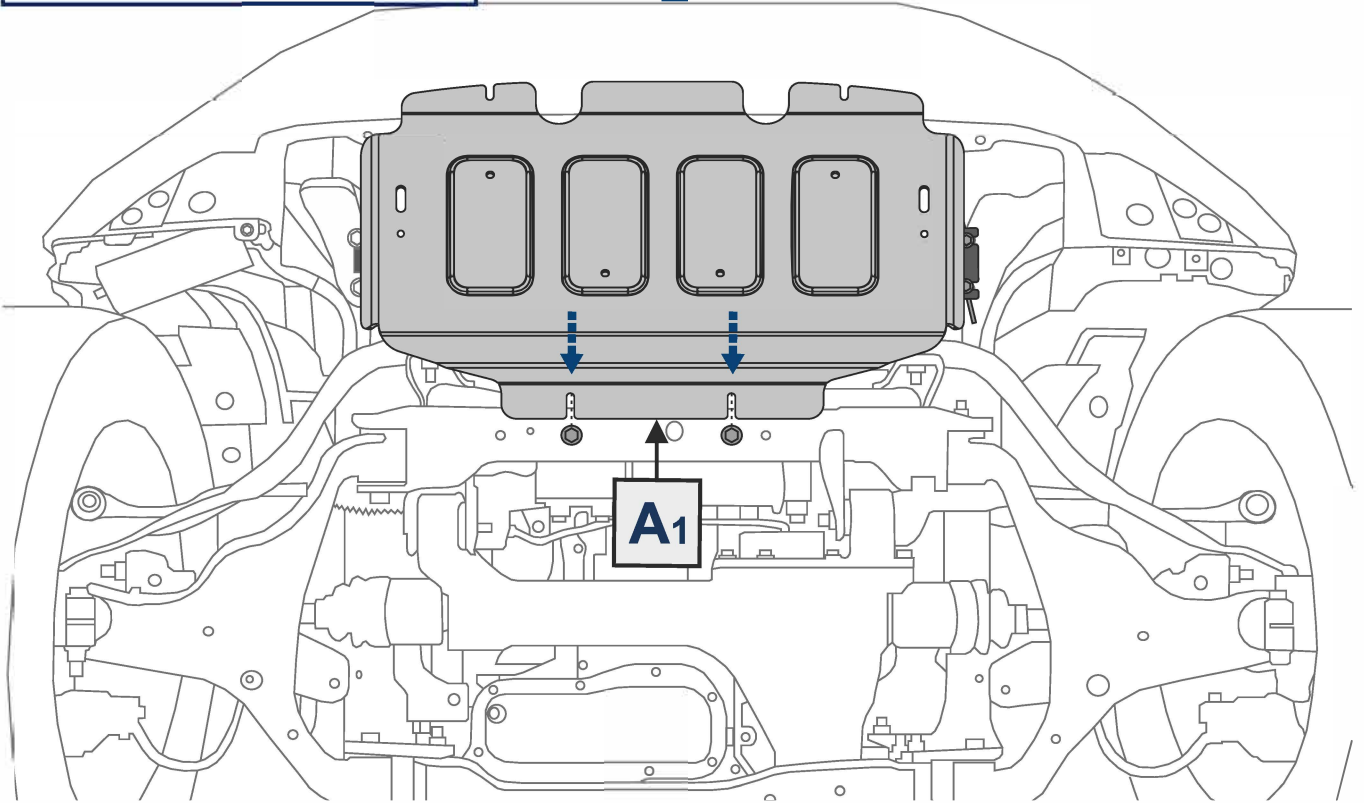

Navara D23/D40

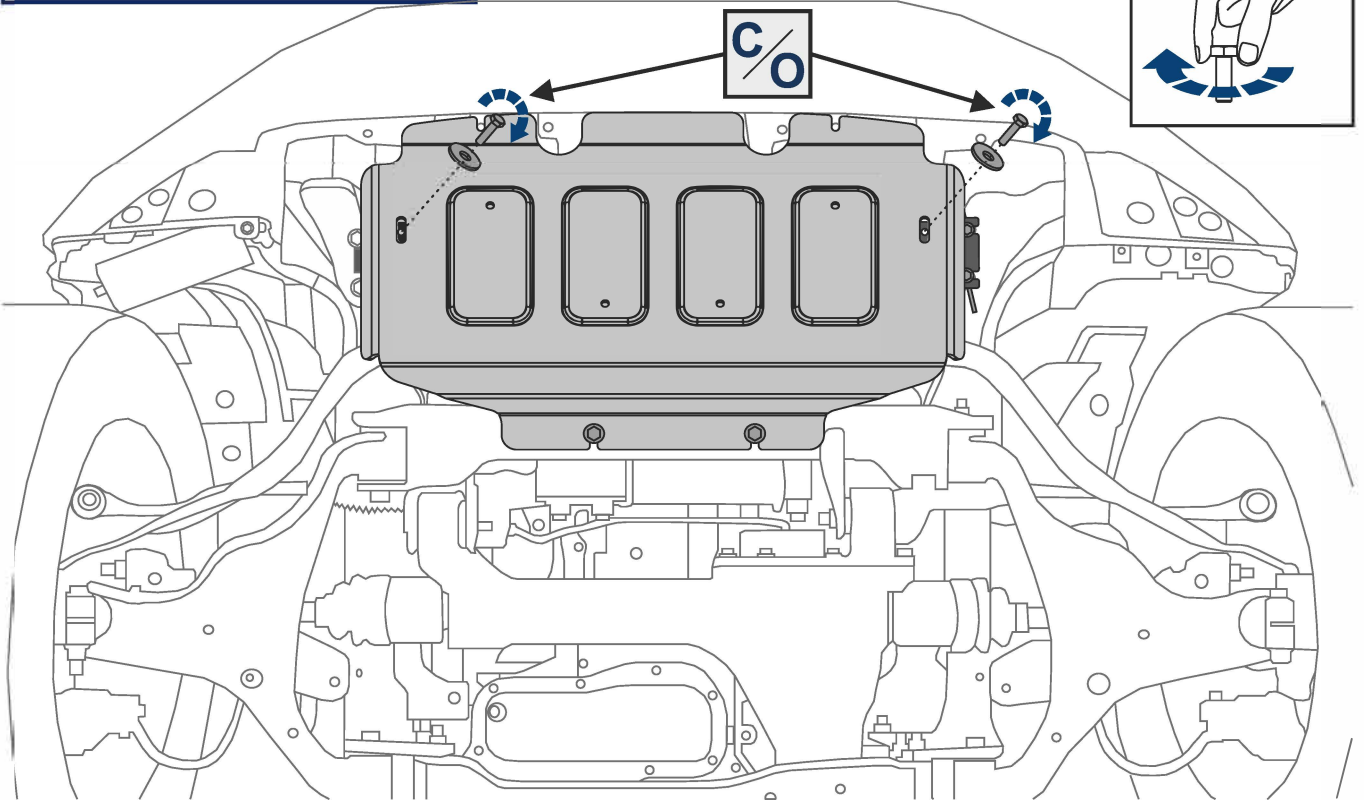
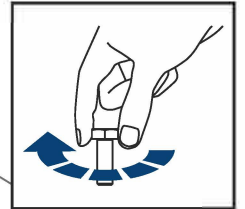

Navara D23

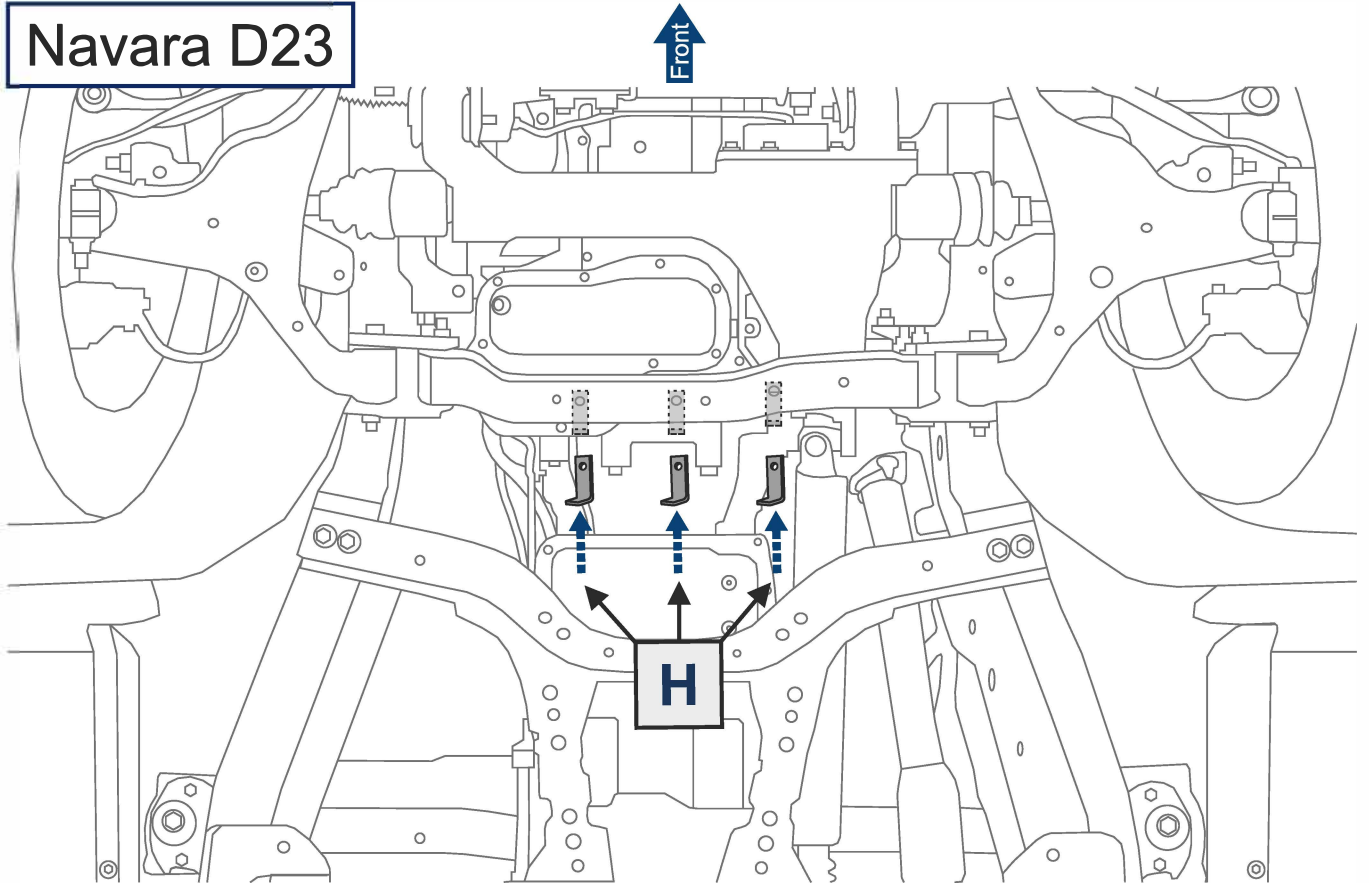

Navara D23

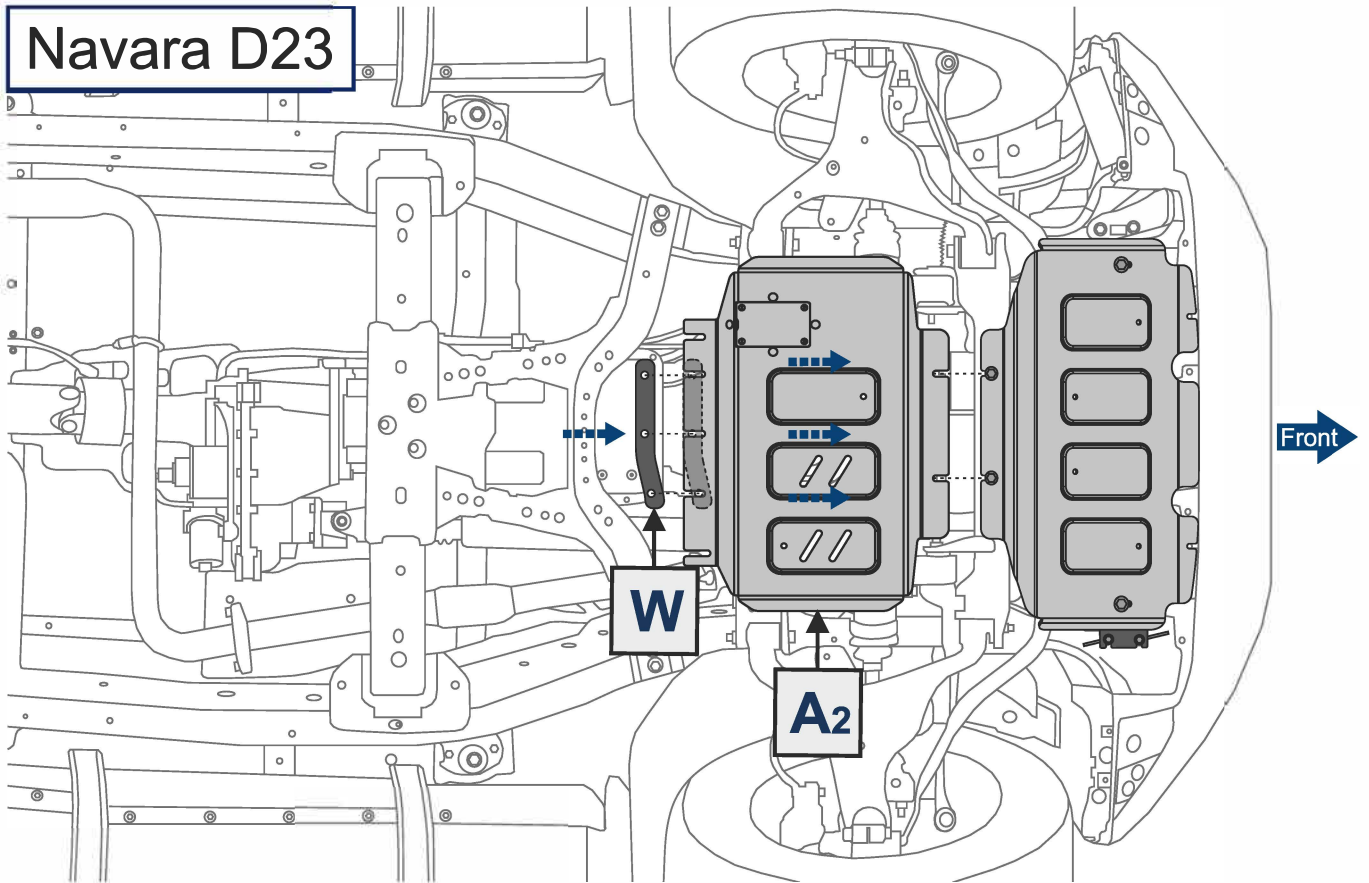

Navara D23

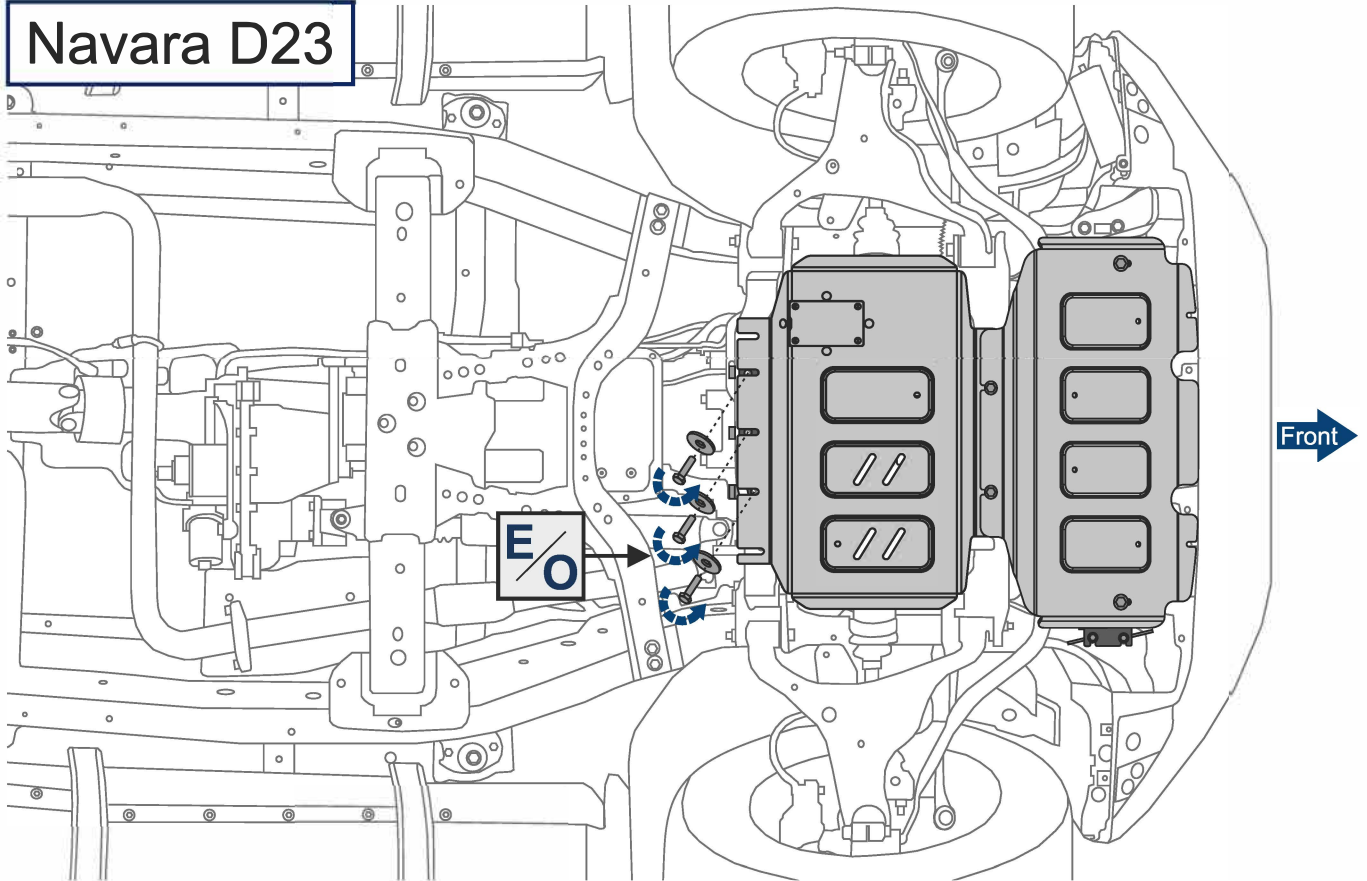

Navara D40

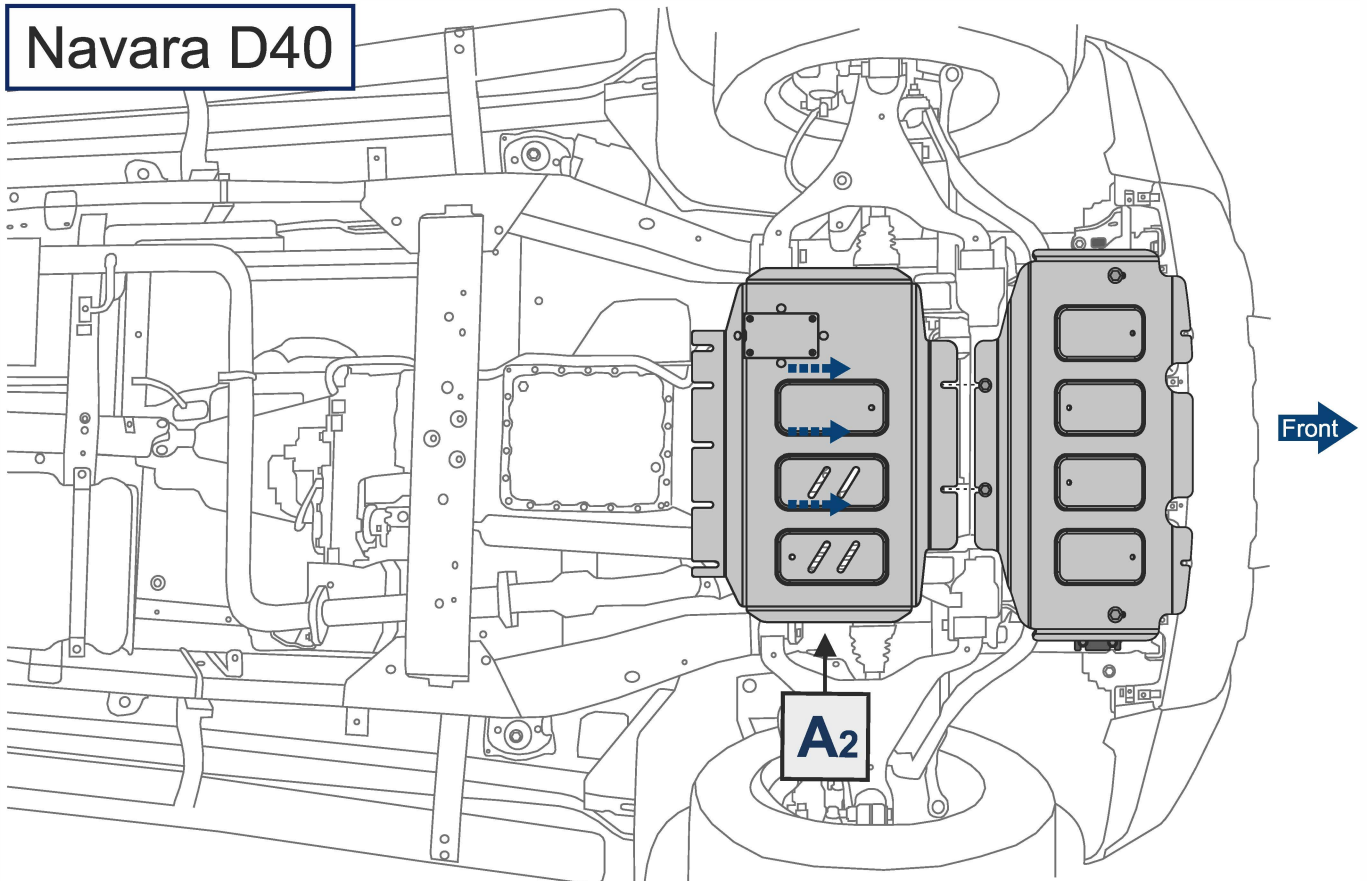

Navara D40

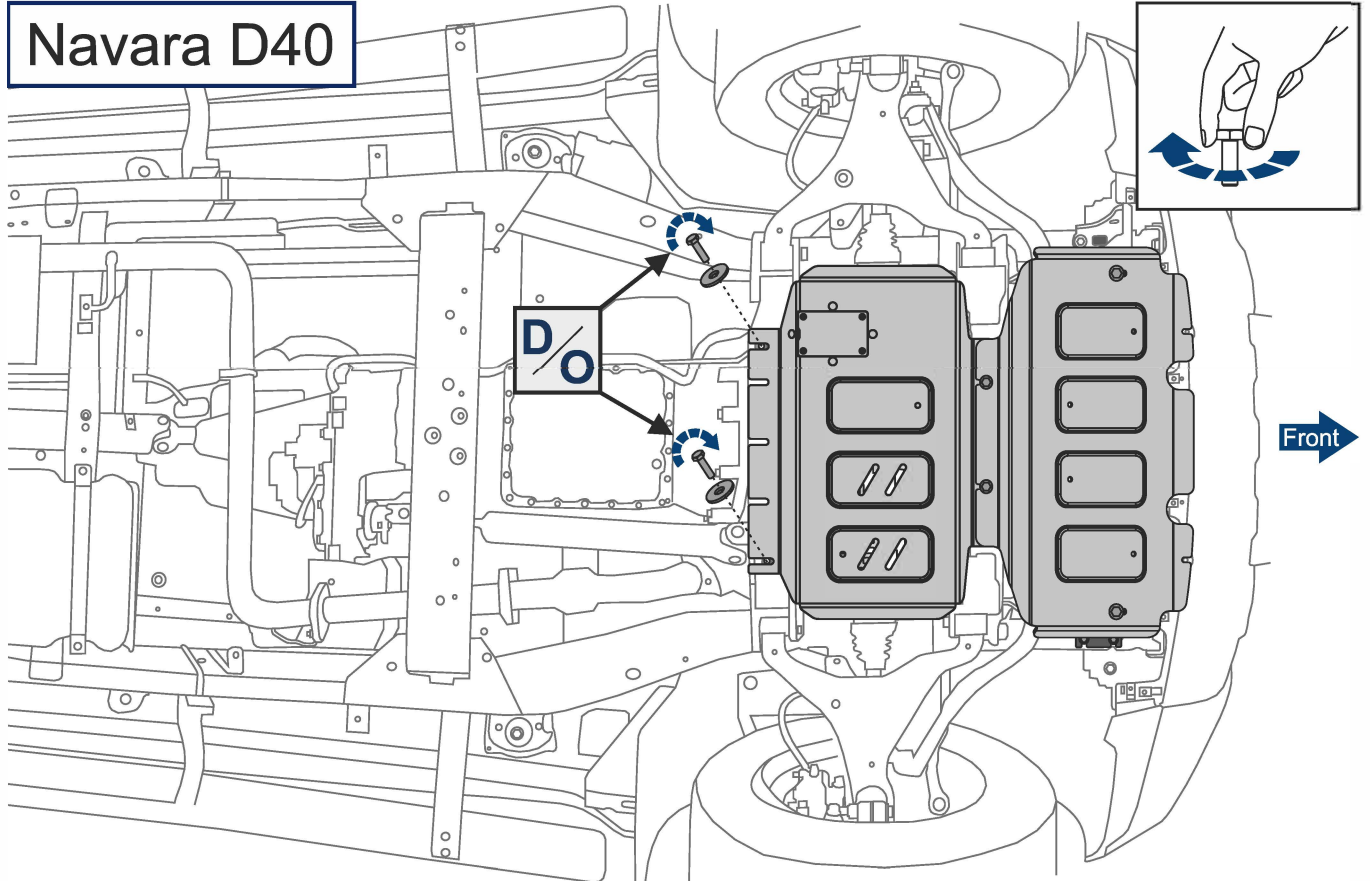

Navara D23

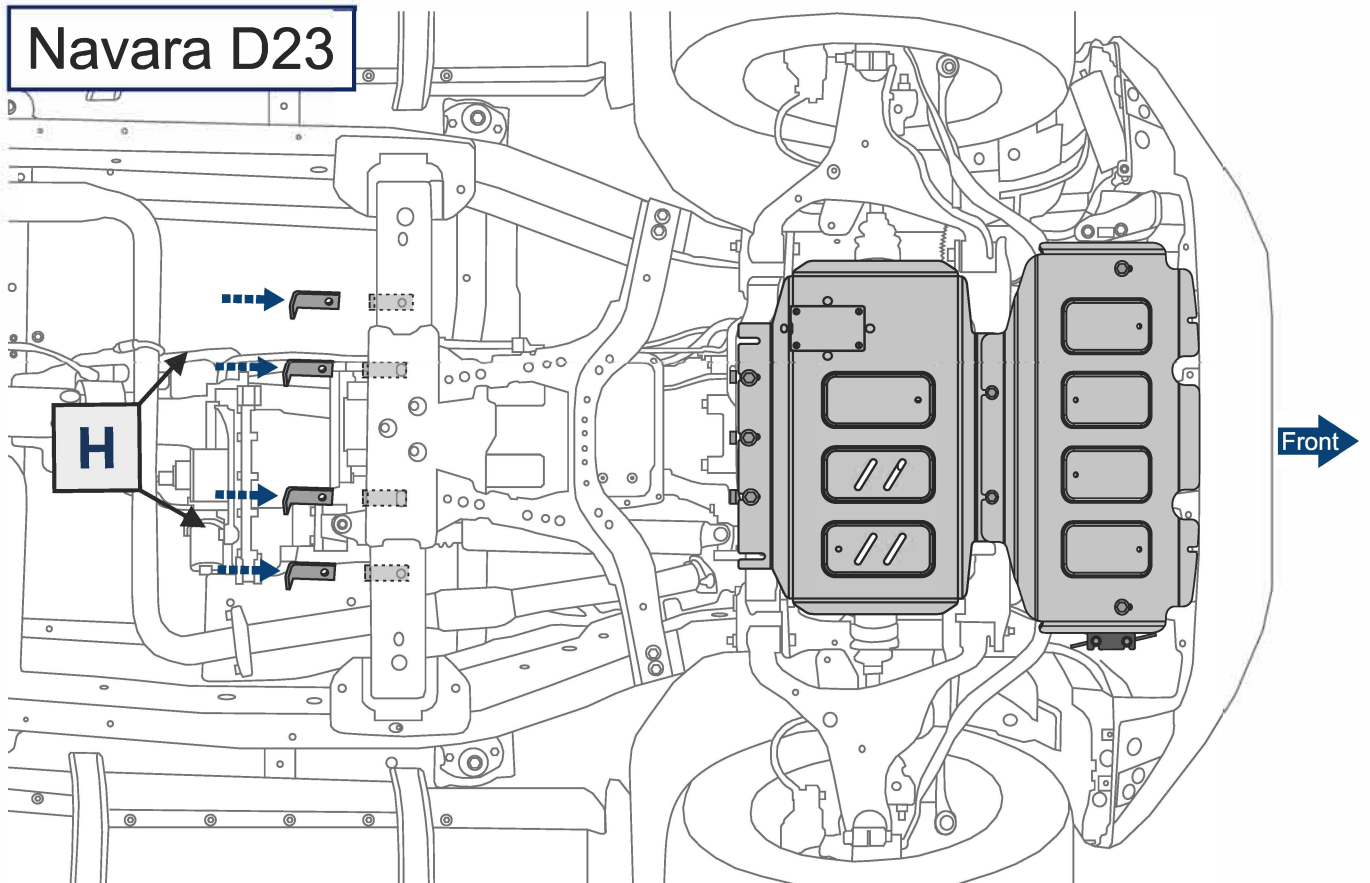

Navara D23

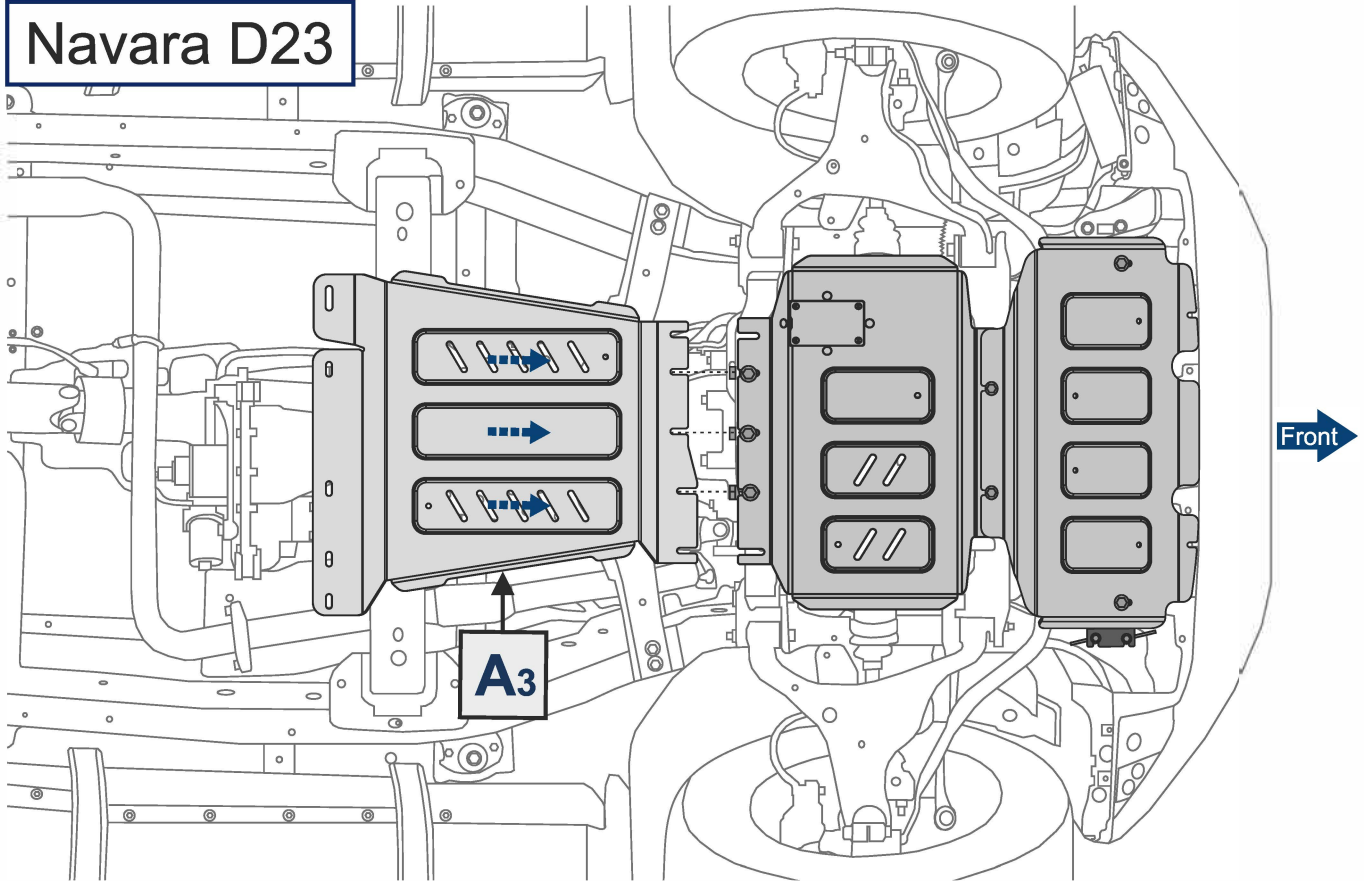

Navara D23

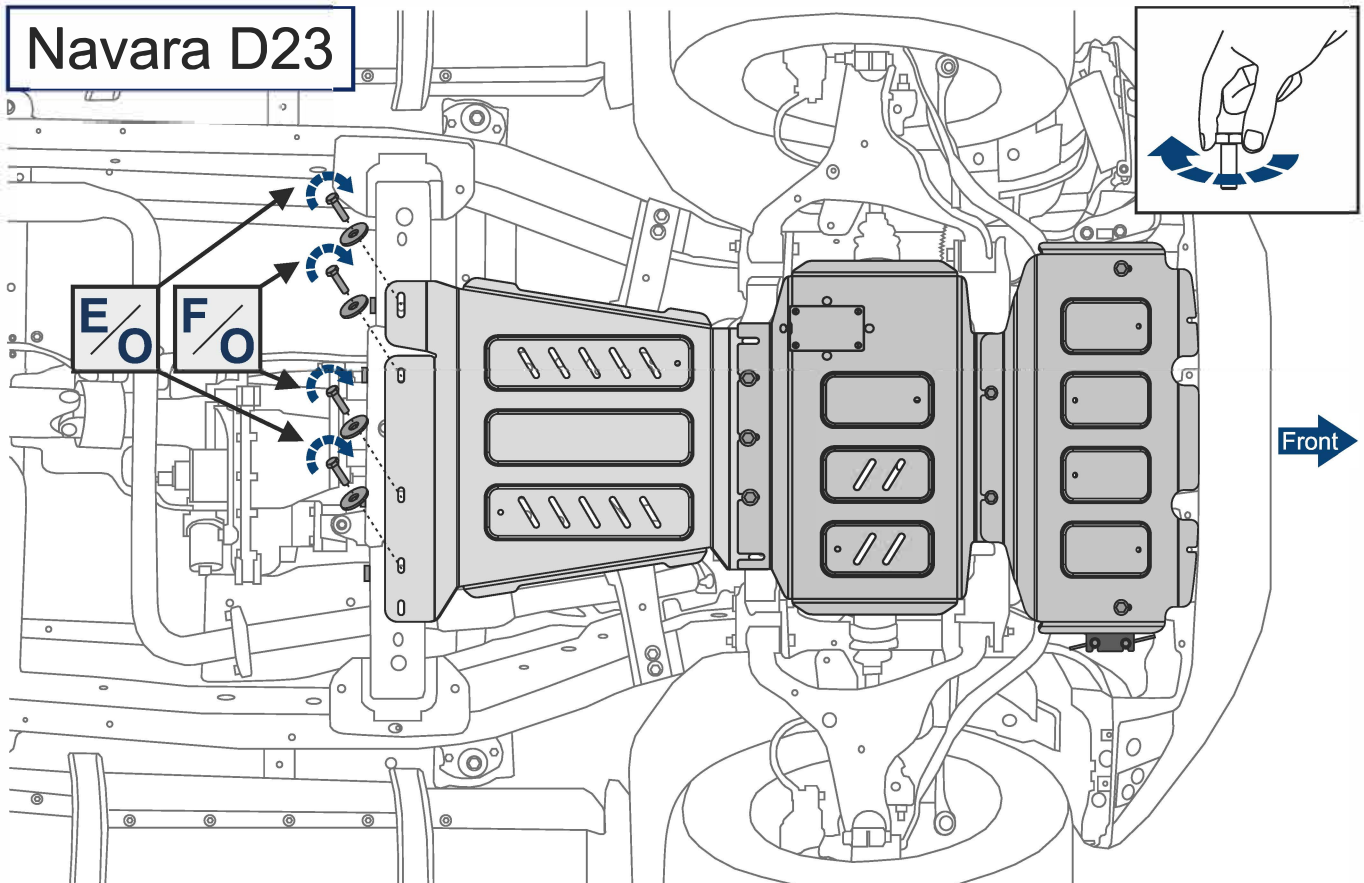

Navara D40

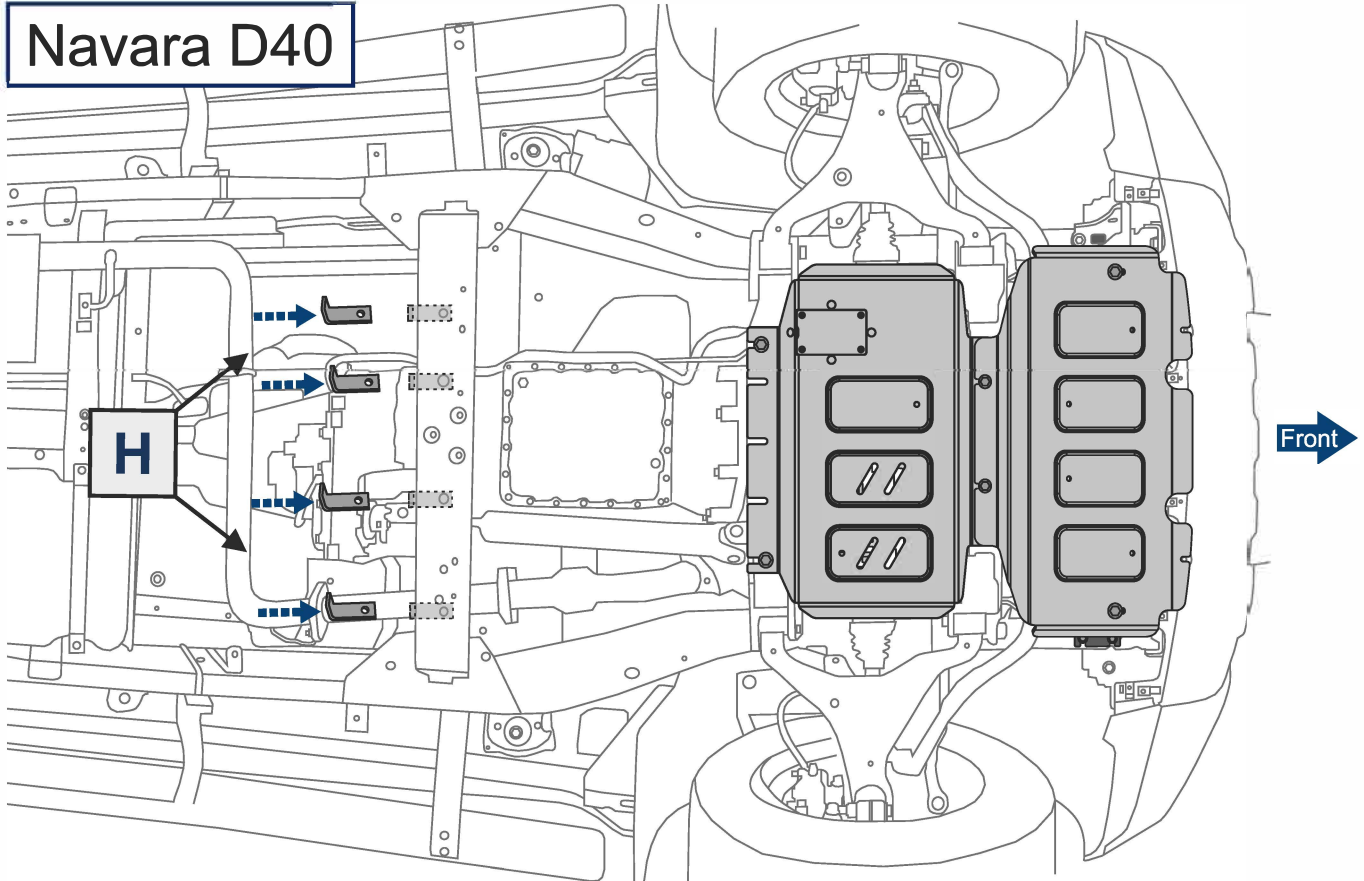

Navara D40

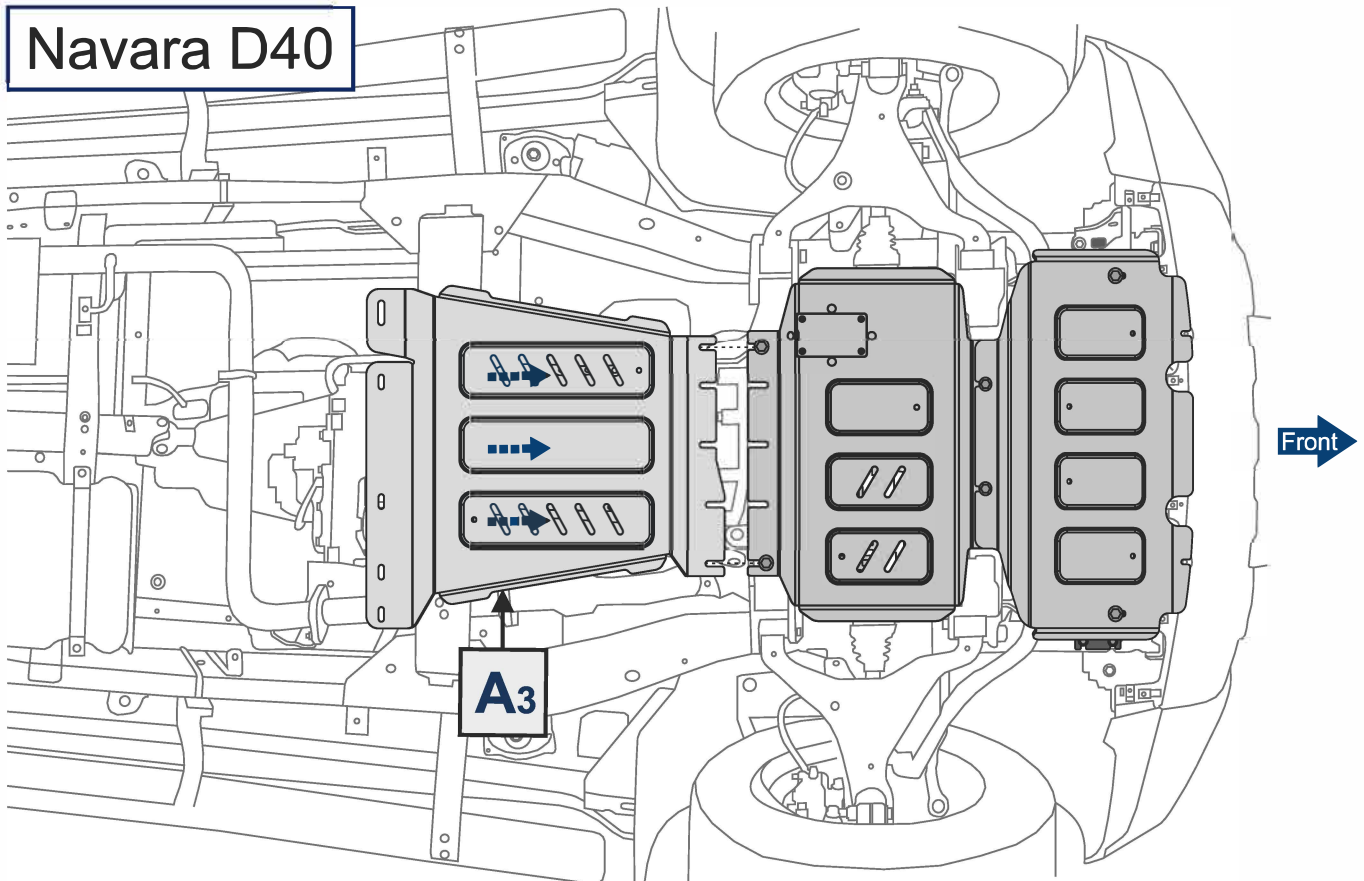

Navara D40

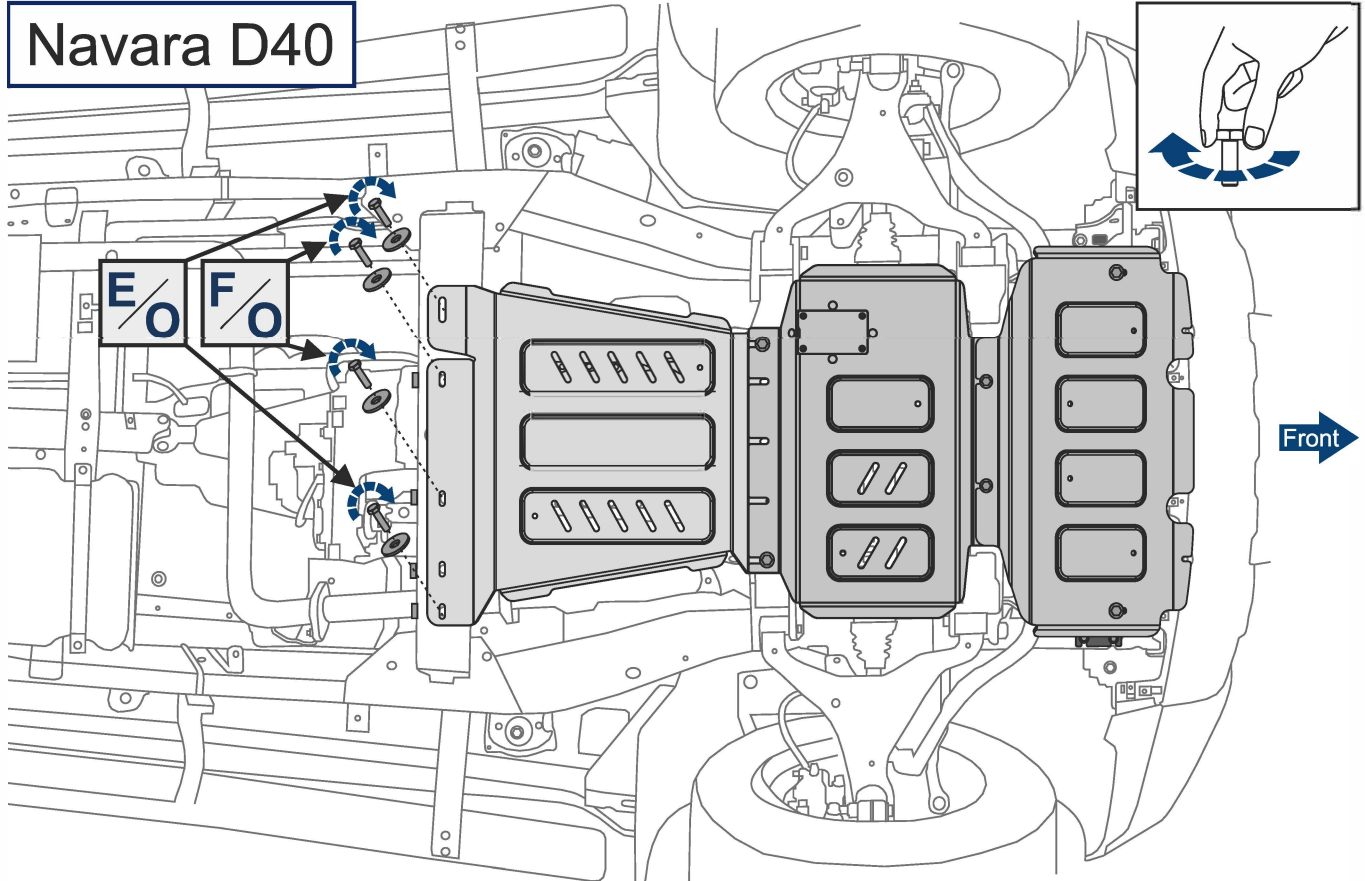

Navara D23/D40 3.0D

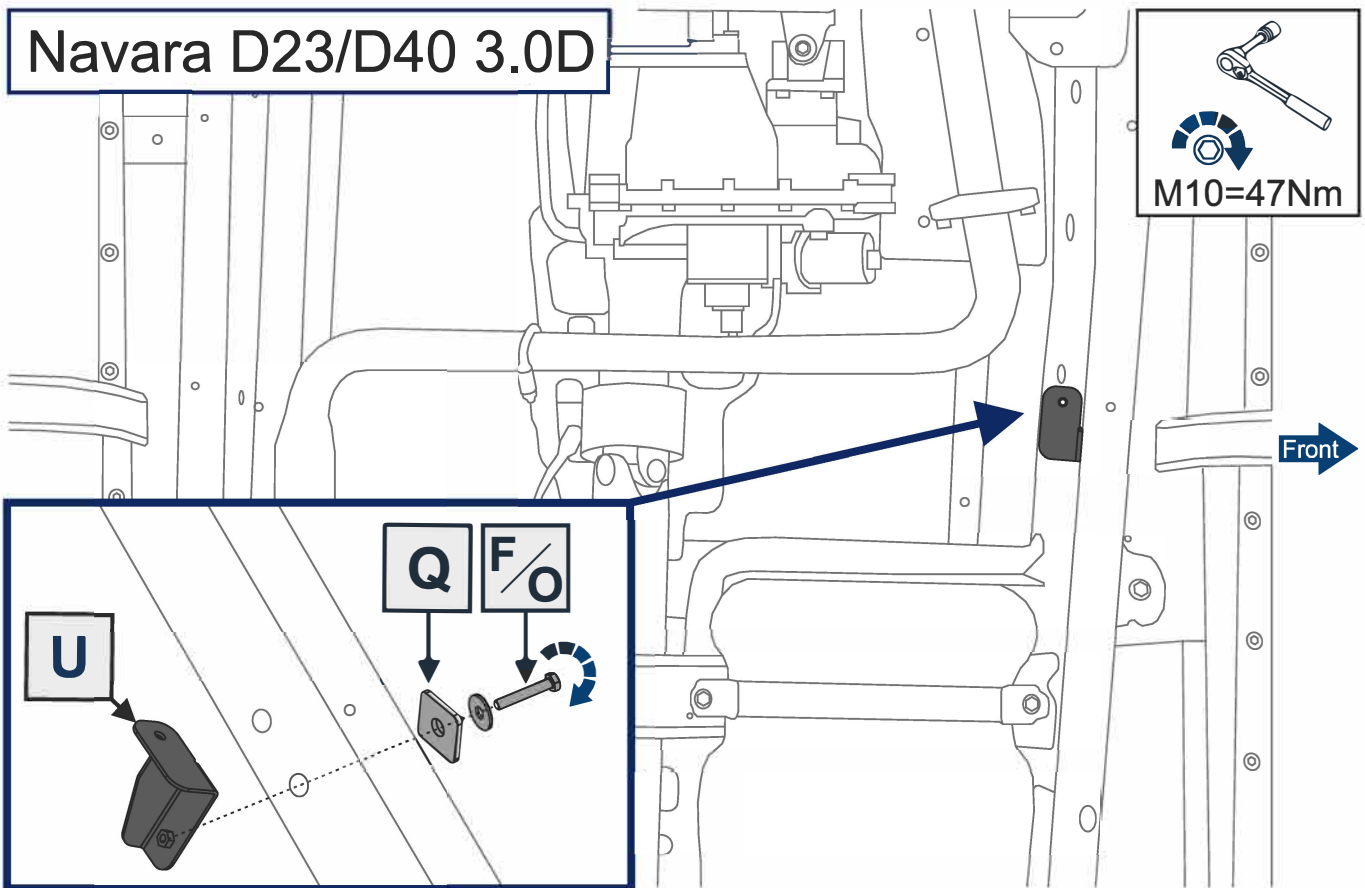

Navara D40 2.5D

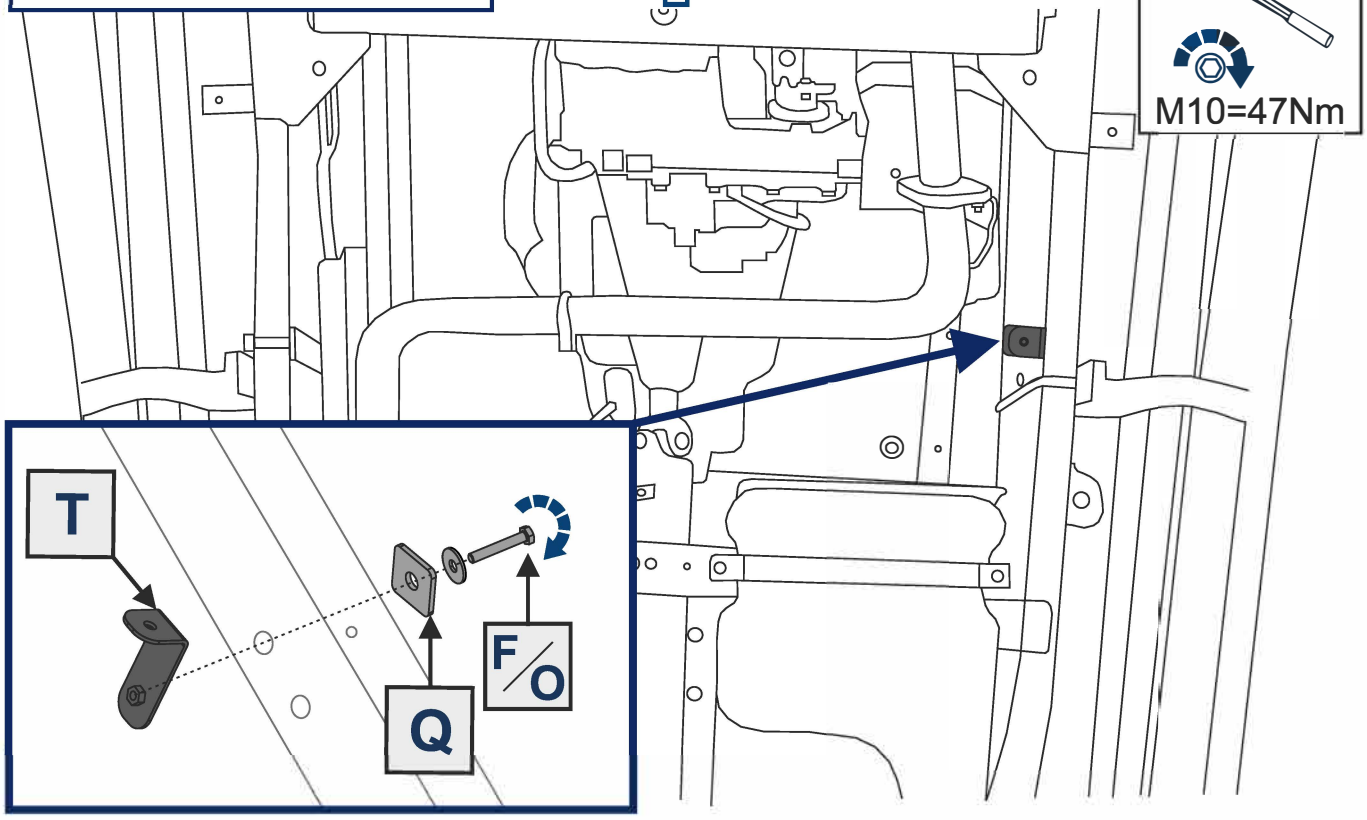
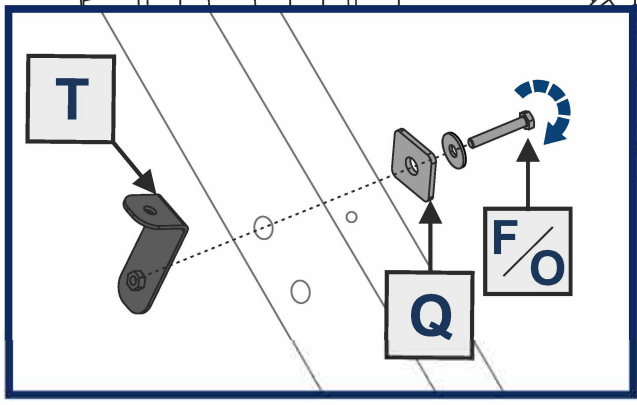

Navara D23/D40

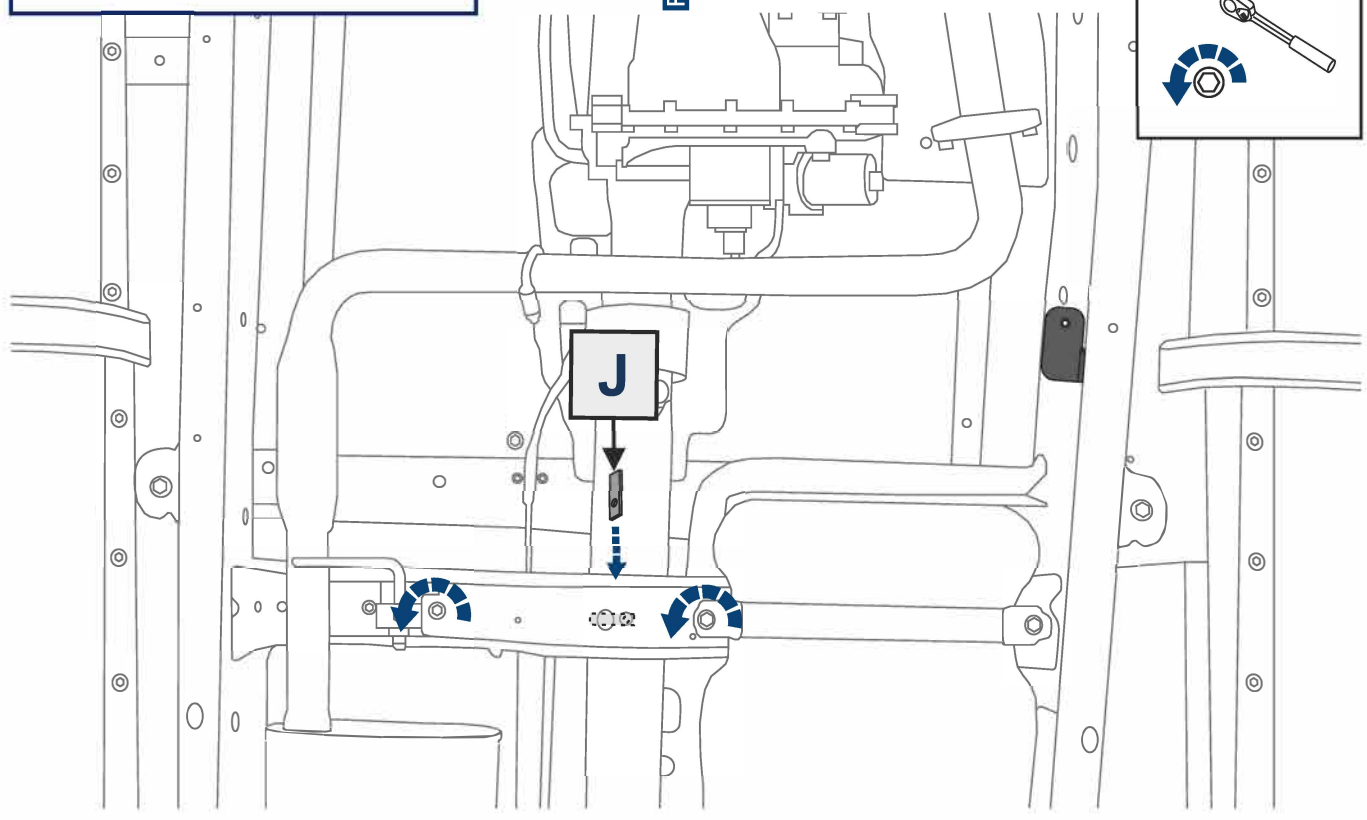
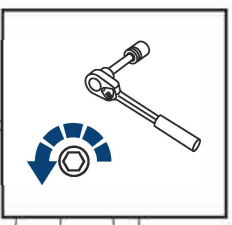

Navara D23/D40

Front ↑

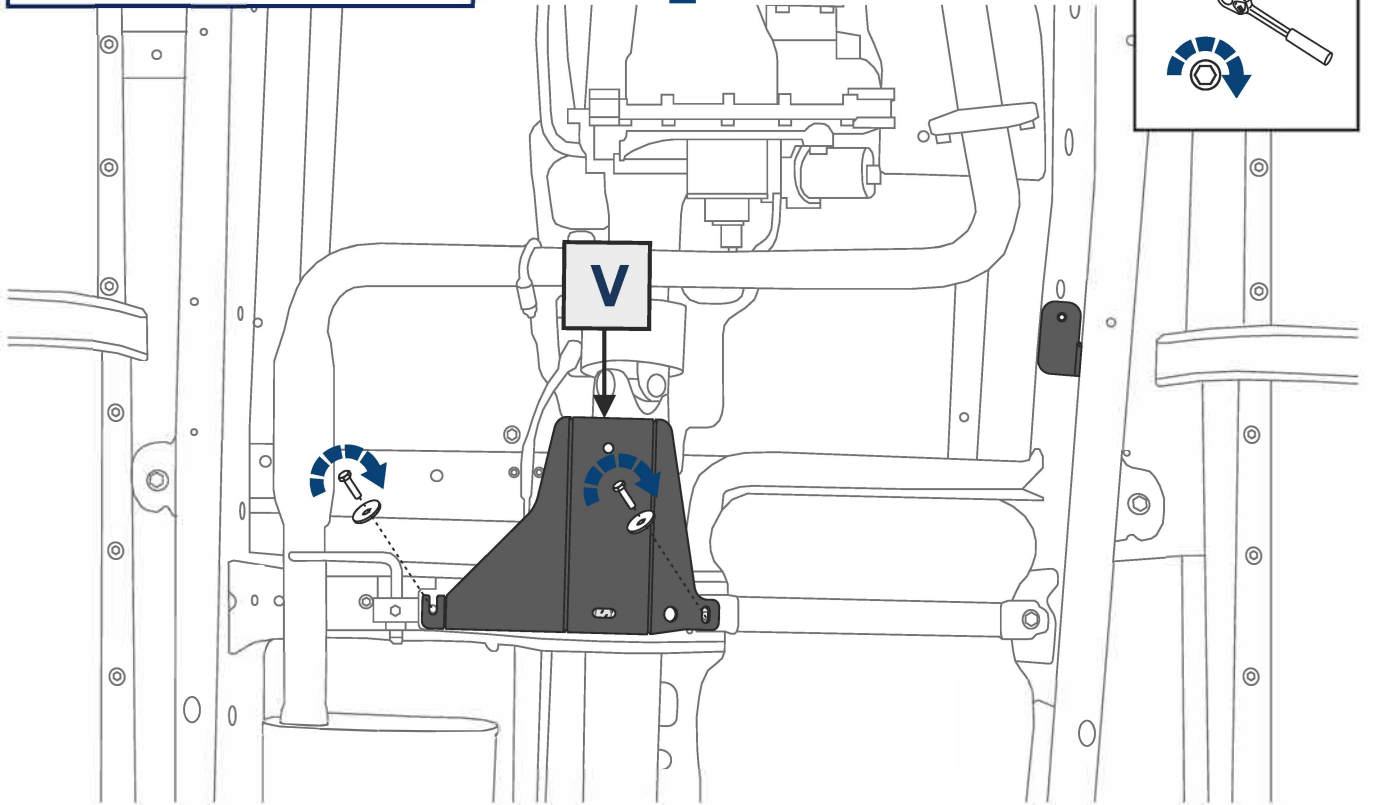
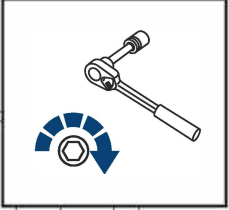

Navara D23/D40

Front ↑

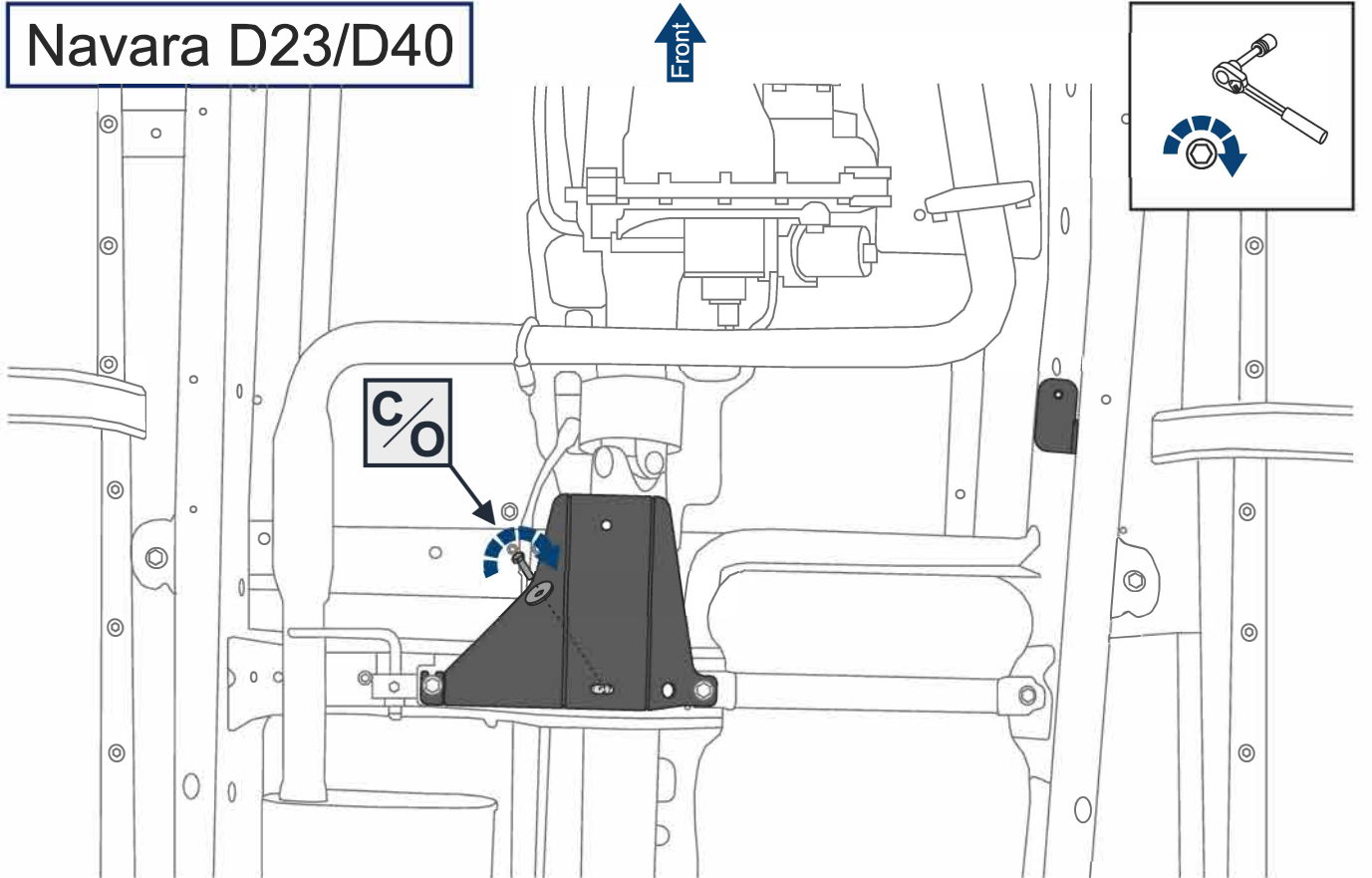
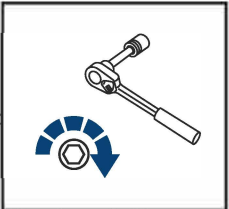

Navara D23/D40

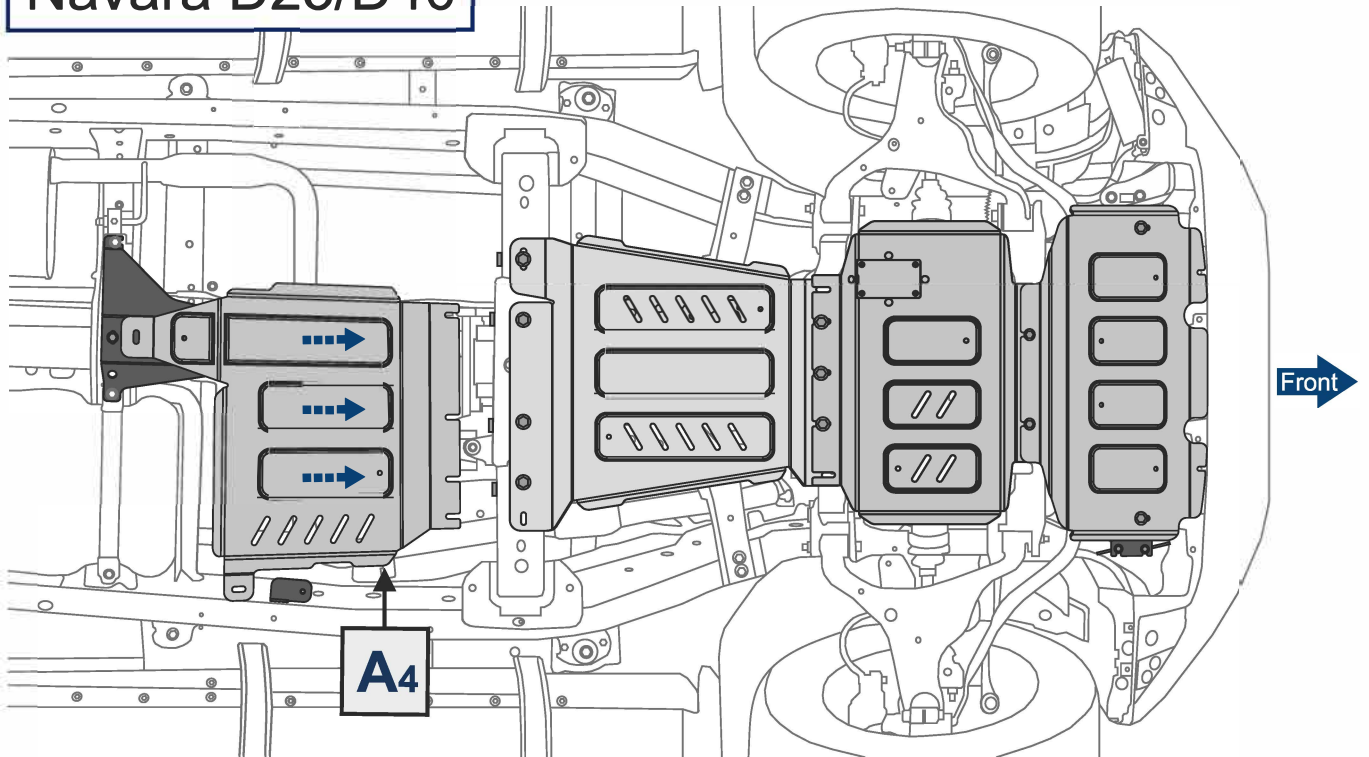

Navara D23/D40

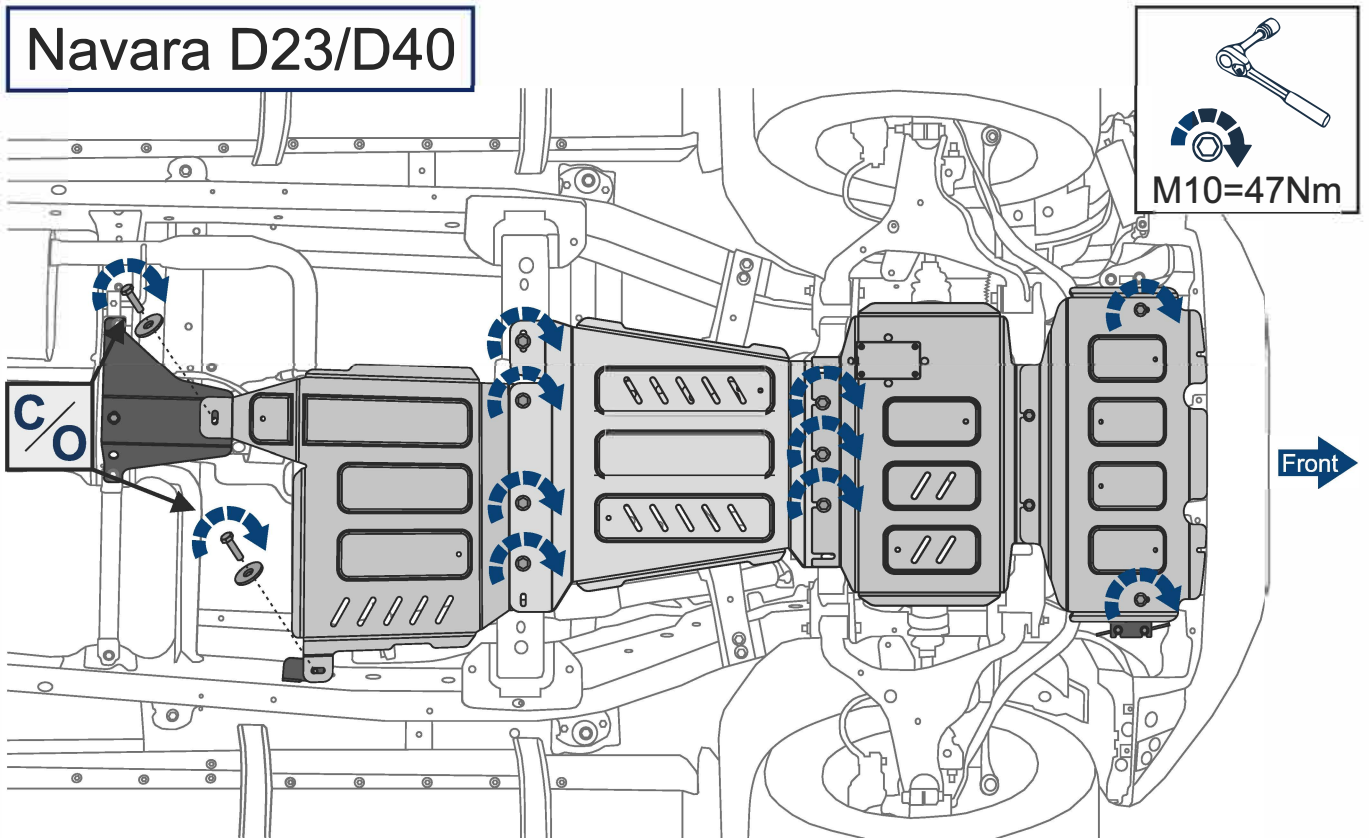

Navara D23/D40

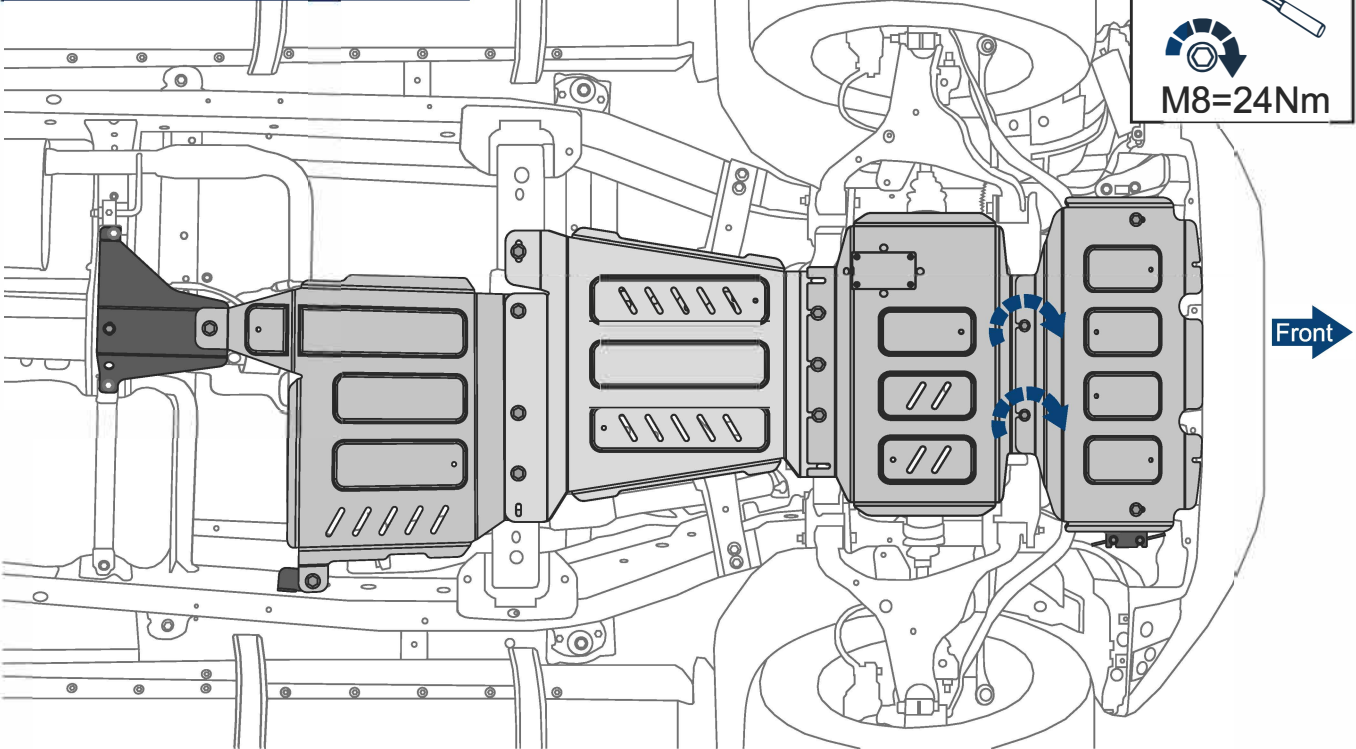

Navara D23/D40

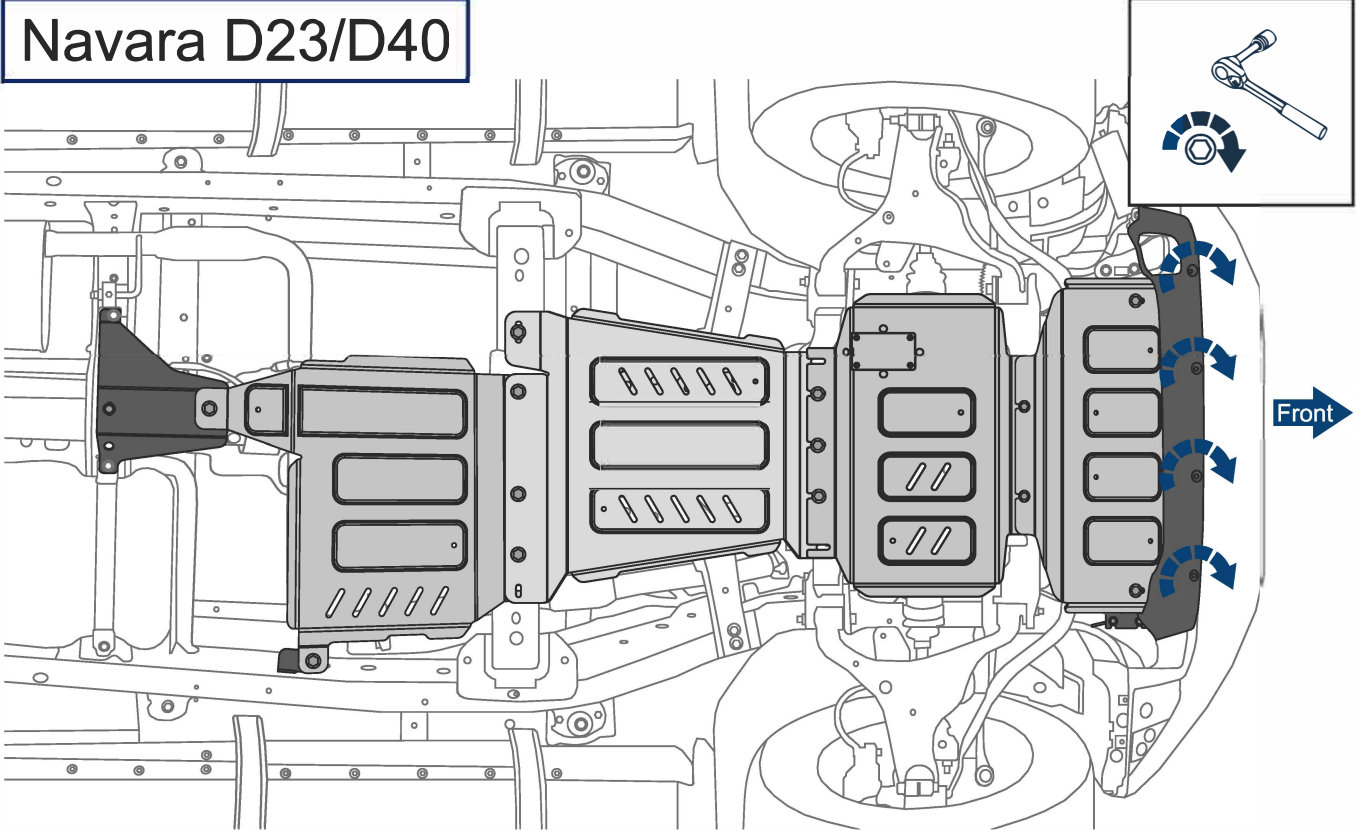

(EN) Mounting requirements:

Underbody Armour is developed individual for each car model.

Underbody Armour must be mounted according to installation manual by an authorized car dealer or by a special car repair stations.

Underbody Armour is to be installed to original points and holes of the power units of the car.

Installed properly Underbody Armour doesn't scrape another parts and assembly of the car.

(DE) Montageanleitung:

Der Unterfahr-/Unterbodenschutz wurde für jedes Fahrzeug individuell entwickelt. Der Unterfahr-/Unterbodenschutz ist gemäß Installationsanleitung des Herstellers bei einer autorisierten Werkstatt oder Autohändler zu montieren. Der Unterbodenschutz wird an den originalen Befestigungsbohrungen der Karosserie montiert. Bei Montage gemäß Herstellervorgaben werden keine anderen Karosserieteile beschädigt oder in Mitleidenschaft gezogen.

(RU) Установка:

Защита разрабатывается индивидуально на каждый автомобиль.

Она должна устанавливаться в соответствии с инструкцией изготовителя специализированным дилером или на сертифицированных СТО.

Защита крепится к штатным отверстиям силовых элементов кузова.

При правильной установке защита не должна касаться узлов и агрегатов автомобиля.

(EN) Working requirements:

Underbody Armour is designed for use and drive of the vehicle in conditions considere by the car manufacture.

While driving the carat speed, cases of collisions with large obstacles and objects need to be excluded.

In the case of a collision with an obstacle Underbody Armour and the vehicle must be inspected in a specialized car repair stations for damage of the components and assemblies and suitability for further use.

(DE) Herstellervorgaben:

Der Unterfahr-/Unterbodenschutz ist gemäß den Vorgaben des Fahrzeugherstellers zu verwenden. Das Befahren und Zusammenstoßen von/mit Hindernissen und großen Objekten ist zu unterlassen. Nach erfolgtem Zusammenstoß muss die Funktionsfähigkeit des Fahrzeuges und/oder entstandene Mängel von einer autorisierten Werkstatt überprüft werden.

(RU) Условия эксплуатации:

Защита предназначена для эксплуатации в условиях предусмотренных производителем автомобиля.

При эксплуатации должны быть исключены случаи наезда на крупные препятствия и предметы при движении автомобиля на скорости.

В случае наезда на препятствие необходимо убедиться в отсутствии повреждений узлов и агрегатов автомобиля и пригодности дальнейшей эксплуатации защиты на специализированном СТО.

EN Warranty:

Warranty period - 12 months.

DE Gewähr:

Die Dauer der Gewährleistung beträgt 12 Monate.

RU Гарантия:

Гарантийный срок эксплуатации - 12 месяцев.

EN Warranty terms and conditions:

Underbody Armour is installed on the car, with good condition of the body and the assembly parts (the car, that was not involved in the accident).

Absence of mechanical damages of the Underbody Armour caused by a head-on crush;

Compliance with all installation requirements;

Absence of powder coating damages of the Underbody Armour;

The manufacturer is not liable for any damage caused to the vehicle, the life and health of people in the event of breach of the installation and using of Underbody Armour. The manufacturer has the right to change the design of Underbody Armour.

DE Gewährleistung:

Der Unterfahr-/Unterbodenschutz muss ohne Beschädigung und/oder Änderungen an Karosserie montiert worden sein. Es dürfen keine Schäden durch die Kollision mit Hindernissen/Gegenständen entstanden sein. Die Vorgaben der Montageanleitung müssen exakt eingehalten werden. Es dürfen keine Schäden/Kratzspuren an der Pulverbeschichtung vorhanden sein. Der Hersteller übernimmt keine Haftung für Fahrzeugschäden jedweder Art und gesundheitliche Gefährdungen durch fehlerhafte Montage und Nutzung des Unterbodenschutzes. Der Hersteller behält sich vor, Design und Konstruktionsänderungen des Unterbodenschutzes zu ändern.

RU Условия предоставления гарантии:

Защита установлена на автомобиль, с неповрежденными силовыми элементами кузова и конструкции (автомобиль, который не участвовал в ДТП);

Отсутствуют механические повреждения защиты, полученные в результате наезда на препятствие;

Соблюдены все требования инструкции по установке защиты;

Отсутствуют механические повреждения порошкового покрытия;

Производитель не несет ответственности за любой ущерб, причиненный автомобилю, жизни и здоровью людей, в случае нарушения условий установки и эксплуатации защиты.

Производитель вправе вносить изменения в конструкцию защиты.

All products are certified
Alle Produkte sind zertifiziert
Вся продукция сертифицирована

