

INSTALLATION MANUAL

PRODUCT: ALUMINUM FRONT BUMPER SKID PLATE

APPLICATION: TOYOTA LAND CRUISER 300 (2020-)

PART NO: 2333.9561.1.6



CAUTION!

To reduce the risk of serious injury or damage to property: Before you start installing and using this product, read the full instructions, pay special attention to the conditions of safe use and recommendations for installation! When installing or maintaining this product, it is necessary to use protective goggles. Check the integrity of the structure and the moment the fastening is tightened every 250 miles (400 kms) of mileage. Do not use this product if there is damage to the structure or fasteners!

NOTICE

Skid plate is an additional protection, but it can not guarantee to protect against all possible damage in collisions. When driving, be careful of objects and terrain that may damage sensitive parts of the vehicle.

FRONT BUMPER SKID PLATE

Part number 2333.9651.1.6

Suited to vehicle: TOYOTA LAND CRUISER 300 (2021-),
VXR, GXR

Material: Aluminum

Compatibility: RIVAL 9559 Engine skid plate



SAFETY NOTICE

- * The RIVAL front bumper skid plate is designed to complement the use and design of the specified vehicle under conditions specified by the vehicle manufacturer.
- * While driving the vehicle at any speed, collision with any other vehicle, animal or object must always be avoided.
- * Following any collision with any other vehicle, animal or object, the RIVAL front bumper skid plate and the vehicle must be inspected by a specialized or suitably qualified vehicle repairer for possible damage to the components and assemblies in order to confirm suitability for further use of the vehicle.
- * It is strongly recommended that you do not operate a vehicle with a damaged front bumper skid plate or its components. In the case of damage, please contact the nearest RIVAL dealer. Vehicle, or where the skid plate has been damaged, is extremely dangerous and must be avoided at all cost.

INSTALLATION NOTICE

- * The RIVAL front bumper skid plate must be mounted and affixed to the vehicle according to this installation manual.
- * Personal safety during the installation process must be adhered to at all times.
- * Do not install this skid plate on vehicle models other than those allowed in this manual.
- * Estimated time for installation: 1 hour.

REQUIRED TOOLS

- * Basic tool kit
- * Torque wrench

TORQUE SETTING

- * M6 - 9.8 H·m (7.2 lb/ft)
- * M8 - 27 H·m (17.7 lb/ft)

PARTS LISTING

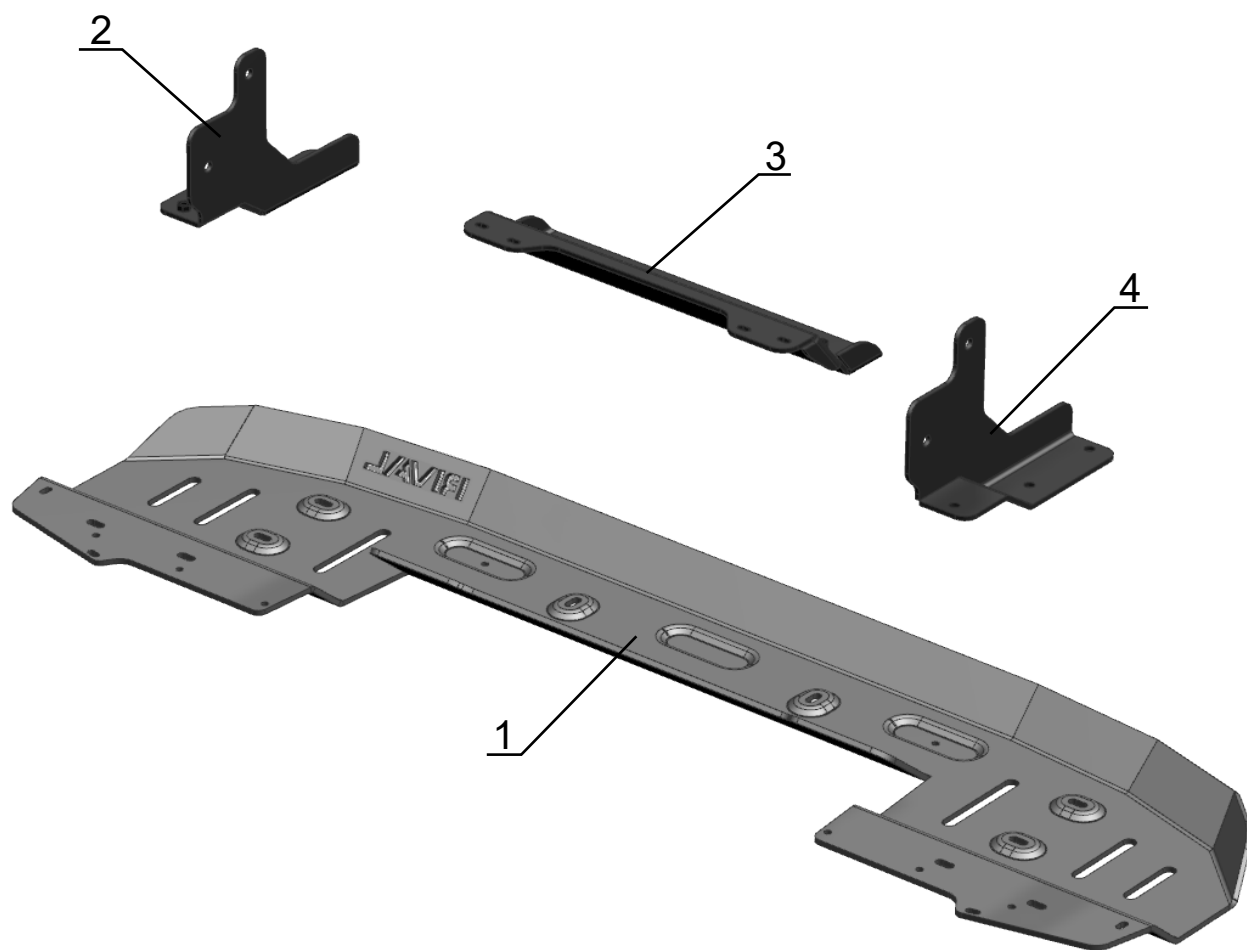

- 1. Front bumper skid plate.....Qty 1
- 2. Left bracket.....Qty 1
- 3. Beam.....Qty 1
- 4. Right bracket.....Qty 1

PARTS LISTING

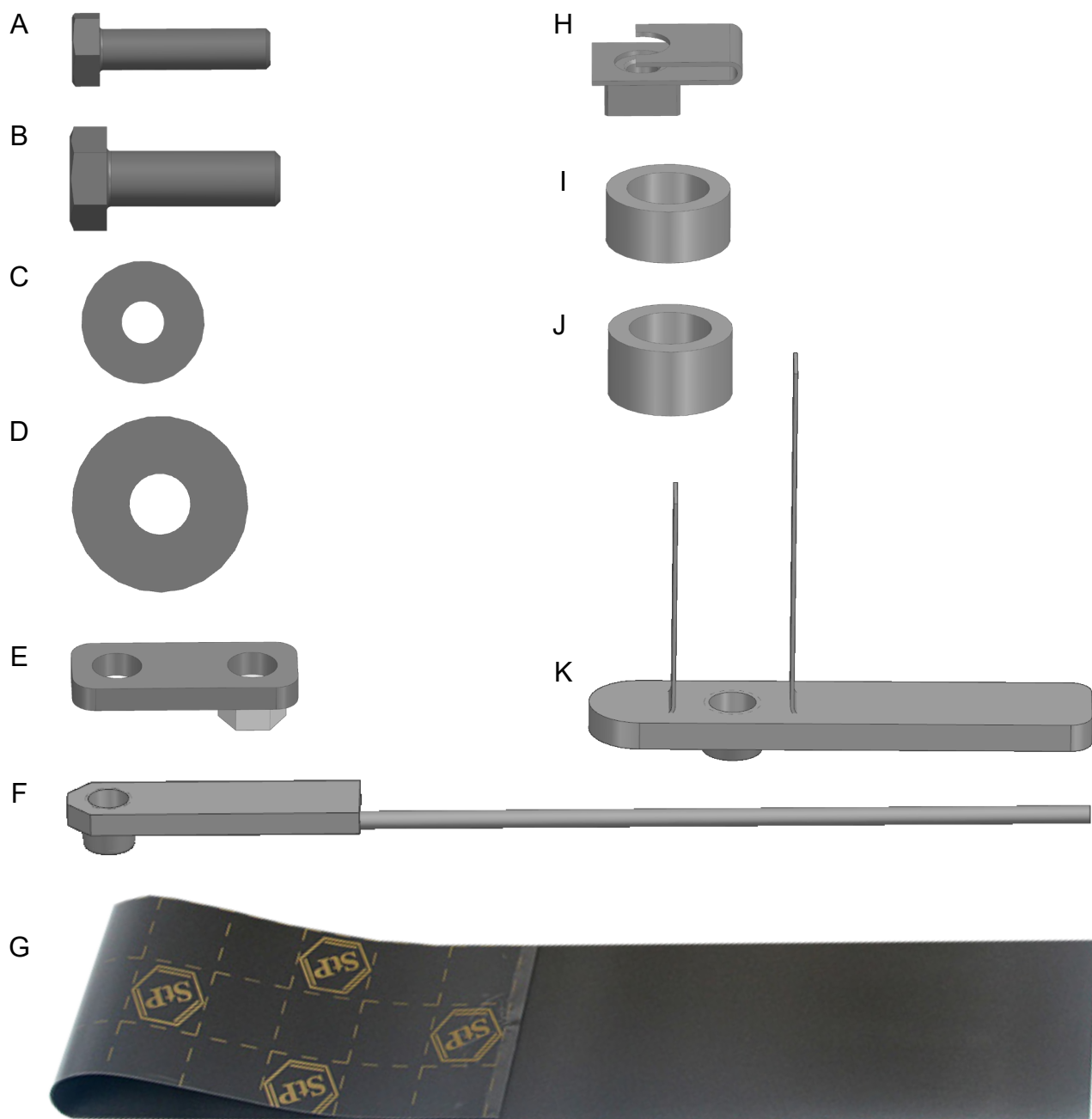

A. Bolt M6x30.....	Qty 6
B. Bolt M8x25 (2 pc. preinstalled, as travel hardware)....	Qty 14
C. Washer 6.....	Qty 6
D. Washer 8 (2 pc. preinstalled, as travel hardware).....	Qty 14
E. Insert nut M8.....	Qty 2
F. Insert nut M8x50 with wire.....	Qty 2
G. Gasket.....	Qty 1
H. Captive nut M6.....	Qty 2
I. Spaser 8mm.....	Qty 2
J. Spaser 10mm.....	Qty 2
K. Insert nut M8x70 with wires.....	Qty 2

INSTALLATION PROCEDURE

***If equipped, remove other aftermarket skid plate.**

***Before installation: Unscrew bolts M8x25 (item B) and washers 8 (item D), preinstalled as travel hardware, in beam (item 3) and skid plate (item 1).**

Set aside to reuse later on.



Fig. 1

1. Unscrew OE screws shown in fig.1 on both sides of the vehicle. Remove OE plastic plate after that (fig. 1)

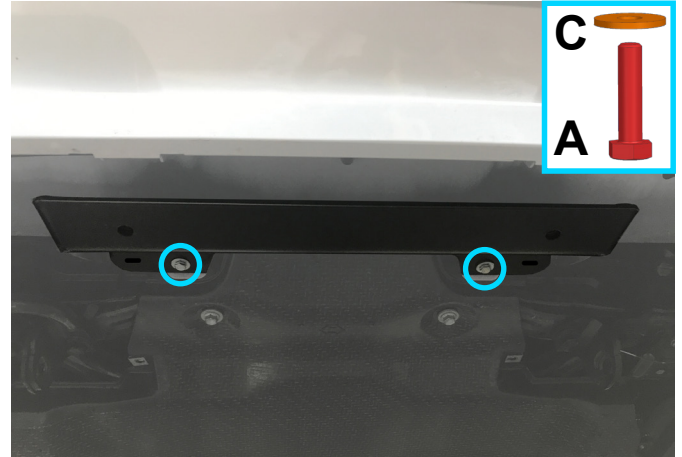

Fig. 2

2. Attach the beam (item 3) using bolts M6x30 (item A) and washers 6 (item C), as shown in fig. 2.

***Do not tighten yet.**



Fig. 3

3. Fix the beam using bolts M6x30 (item A), washers 6 (item C) and spacers 8mm (item I), as shown in fig. 3 and fig. 4.

***Tighten hardware after that.**

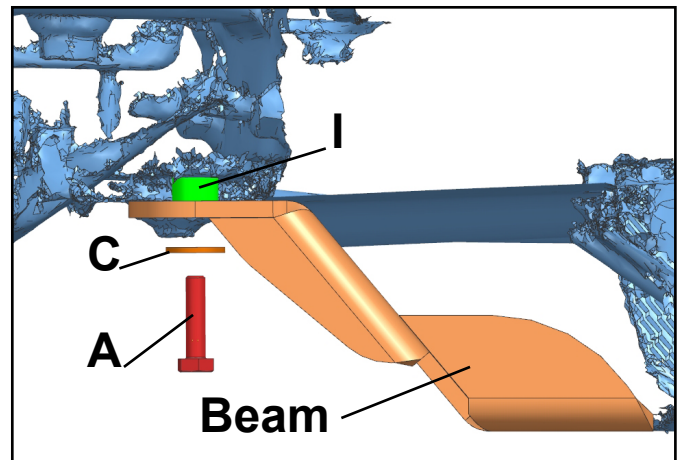

Fig. 4

INSTALLATION PROCEDURE



Fig. 5

4. Attach insert nuts M8 (item E) to plastic plate using OE bolts, as shown in fig.5 on both sides of the vehicle.

***Do not tighten yet.**

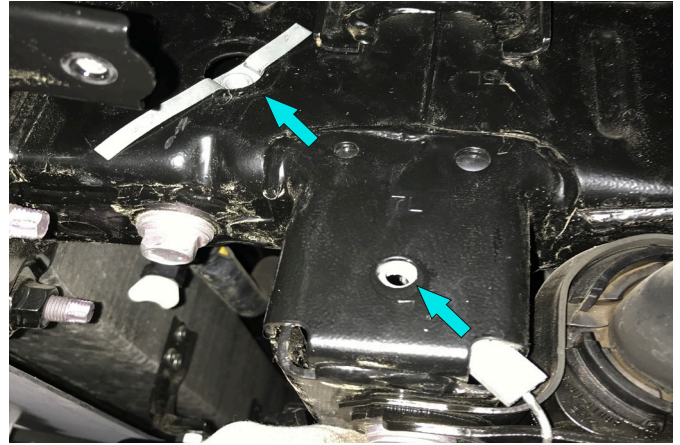

Fig. 6

5. Install insert nuts M8x70 with wires (item K) and insert nuts M8x50 with wire (item F), as shown in fig.6 on both sides of the vehicle.

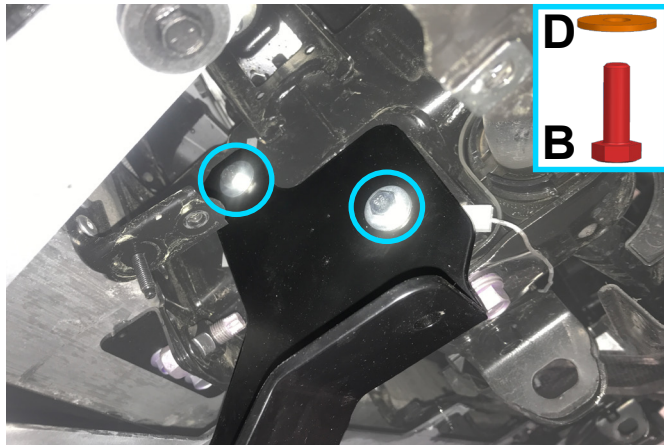

Fig. 7

6. Attach left bracket (item 2) and right bracket (item 4) to insert nuts M8x70 with wires (item K) and insert nuts M8x50 with wire (item F) using bolts M8x25 (item B) and washers 8 (item D), as shown in fig.7 and fig.8 on both sides of the vehicle.

***Tighten hardware after that.**



Fig. 8

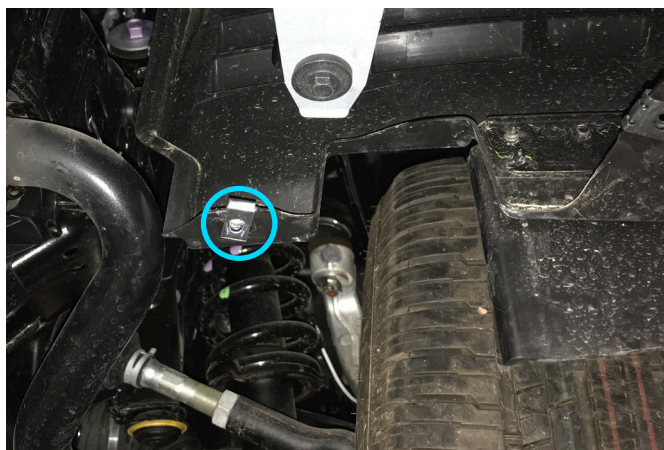

Fig. 9

7. Replace OE captive nuts with captive nuts M6 (item H), as shown in fig.9 on both sides of the vehicle.

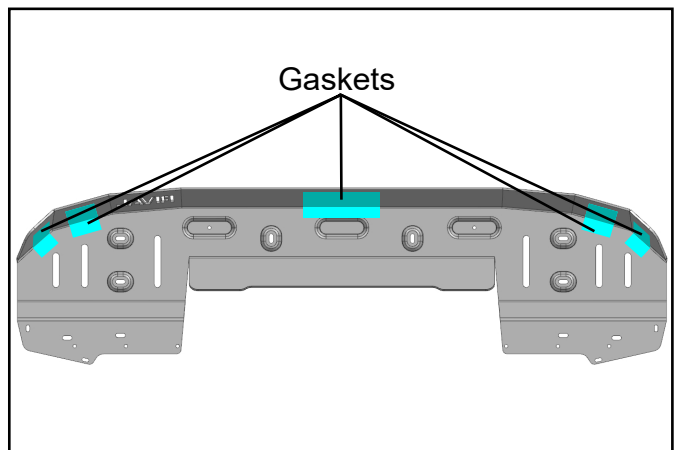

Fig. 10

8. Cut the gasket (item G) and glue to front bumper skid plate (item 1) as shown in fig.10.

INSTALLATION PROCEDURE



Fig. 11

9. Install the front bumper skid plate (item 1) using bolts M8x25 (item A) and washers 8 (item D), as shown in fig.11.

***Tighten hardware after that.**



Fig. 12

10. Unscrew OE bolts and remove mudflaps from the removed OE plastic plate from step 1, as shown in fig.12.



Fig. 13

11. Attach OE mudflaps to the front bumper skid plate (item 1) using OE bolts, as shown in fig.11.

***Tighten hardware after that.**



Fig. 14

12. Fix the rear part of front bumper skid plate to installed captive nuts M6 (item H) from step 7 using bolts M6x30 (item A), washers 6 (item C) and spacers 10 mm (item J) as shown in fig.12.

***Tighten hardware after that.**

INSTALLATION PROCEDURE

Before operating a vehicle fitted with RIVAL Skid Plate:

- make sure all fittings are tightened;
- ensure the integrity of the structure and its components.



EN ENGINE BAY PROTECTION INSTALLATION MANUAL

DE MONTAGEANLEITUNG FÜR MOTORSCHUTZ



**Underbody Armour for:
Toyota Land Cruiser 300 (2021-)**

2333.9559.1.6



EN Regular fasteners
DE Originale montageile

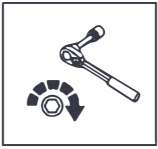

EN Regular fasteners
DE Originale montageile

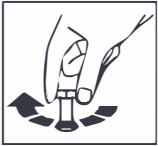

EN Screw a several turns
DE Für wenigen Umdrehungen befestigen

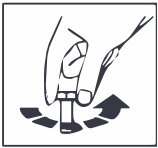

EN Loosen bolts
DE Bolzen lockern

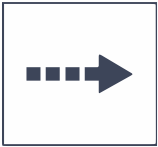

EN Movement Arrow
DE Bewegungsrichtung

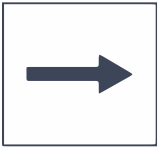

EN Location/Position Arrow
DE Anordnung/Positionsrichtung



EN Screw Arrow
DE Drehungsrichtung

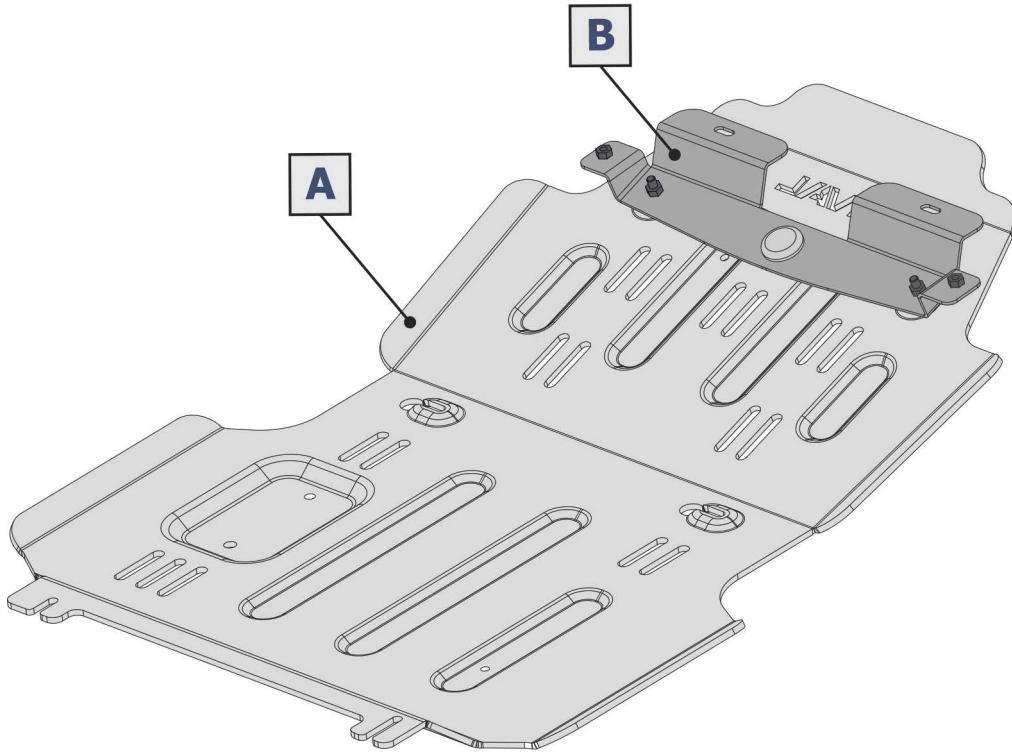
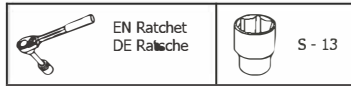

<p>1</p>  <p>x1</p>	<p>2</p>  <p>x2</p>	<p>3</p>  <p>M8x20 x4</p>	<p>4</p>  <p>M8x30 x4</p>	<p>5</p>  <p>M8x40 x2</p>	<p>6</p>  <p>Ø8 x10</p>
--	---	---	---	---	---

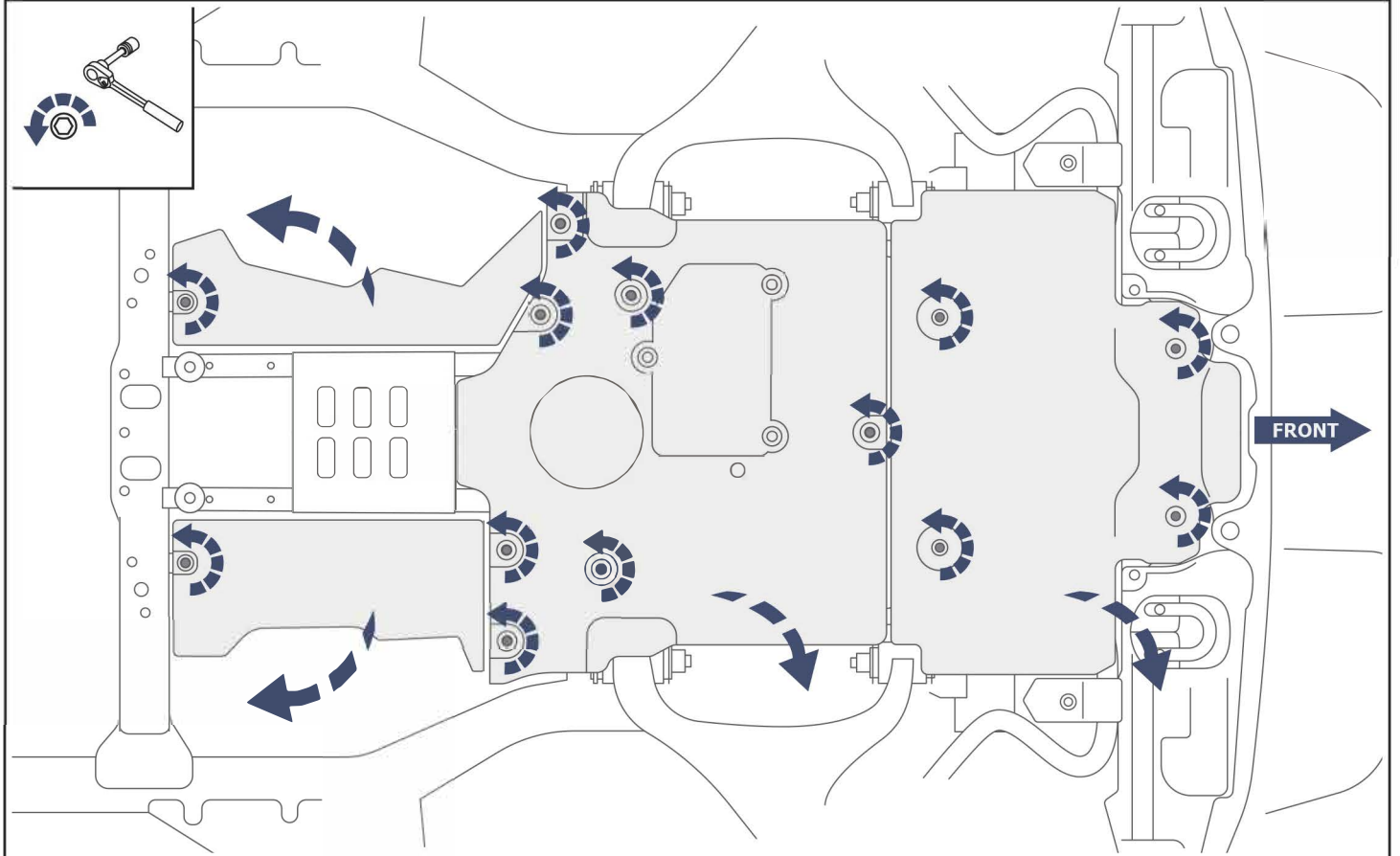
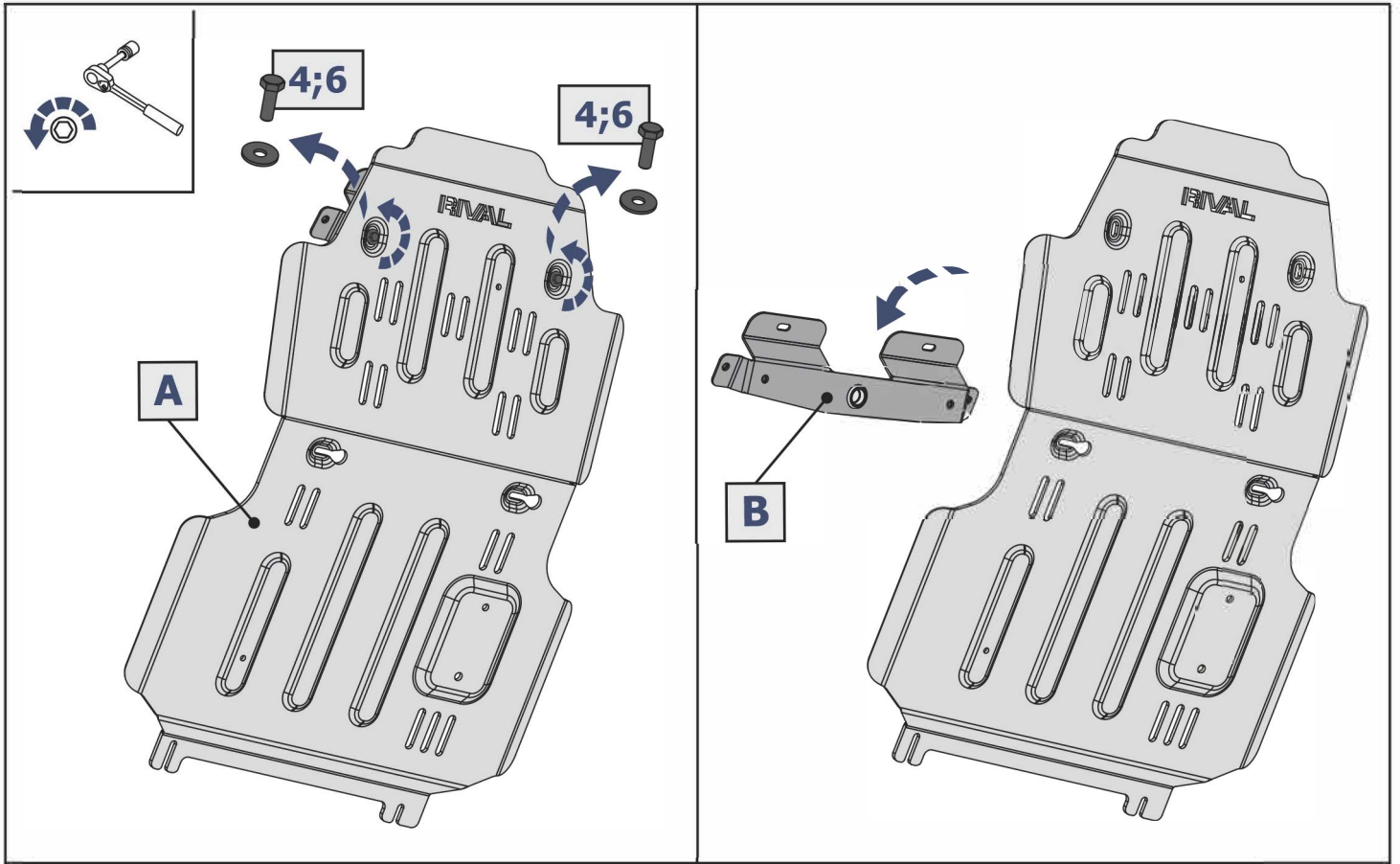

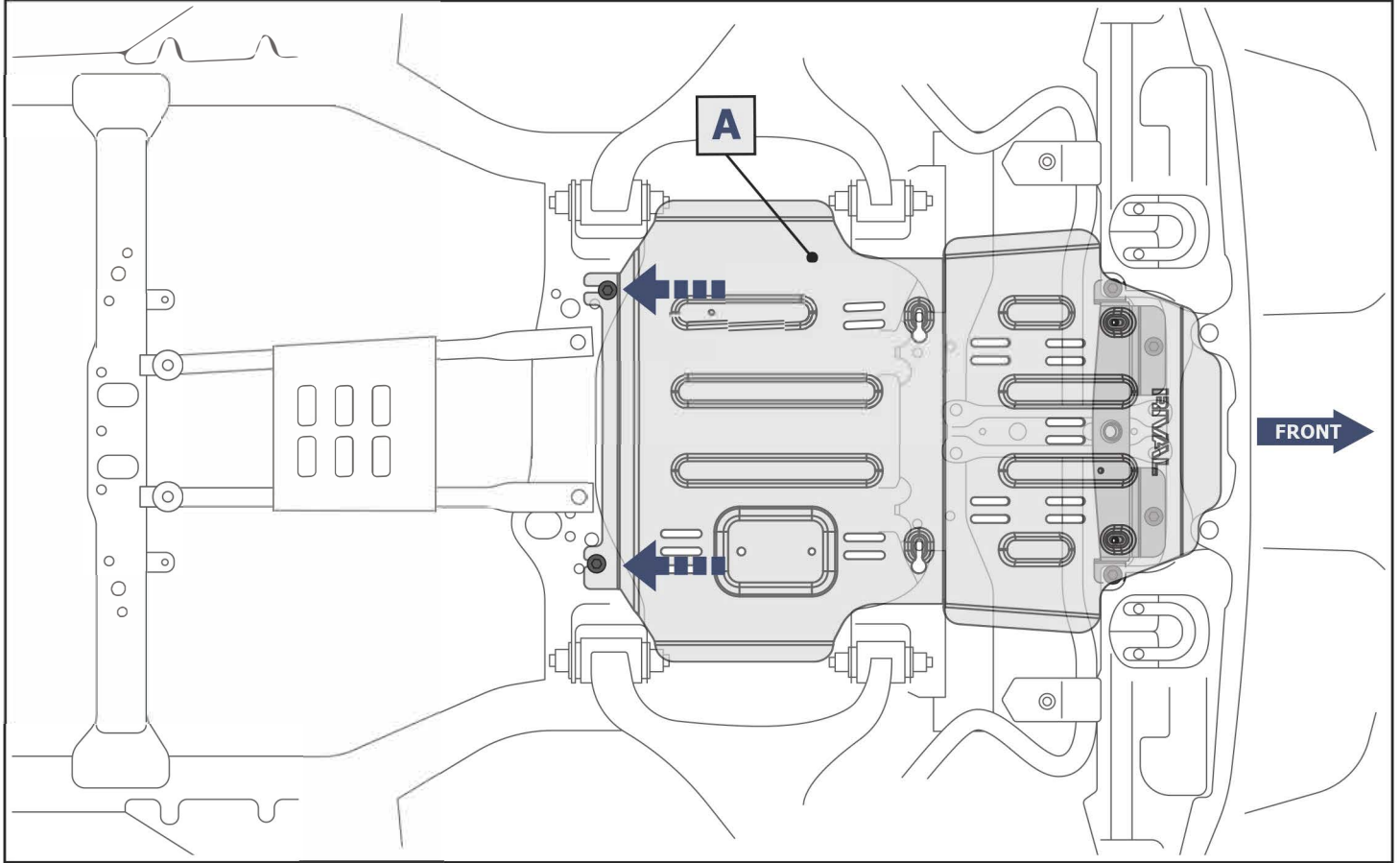
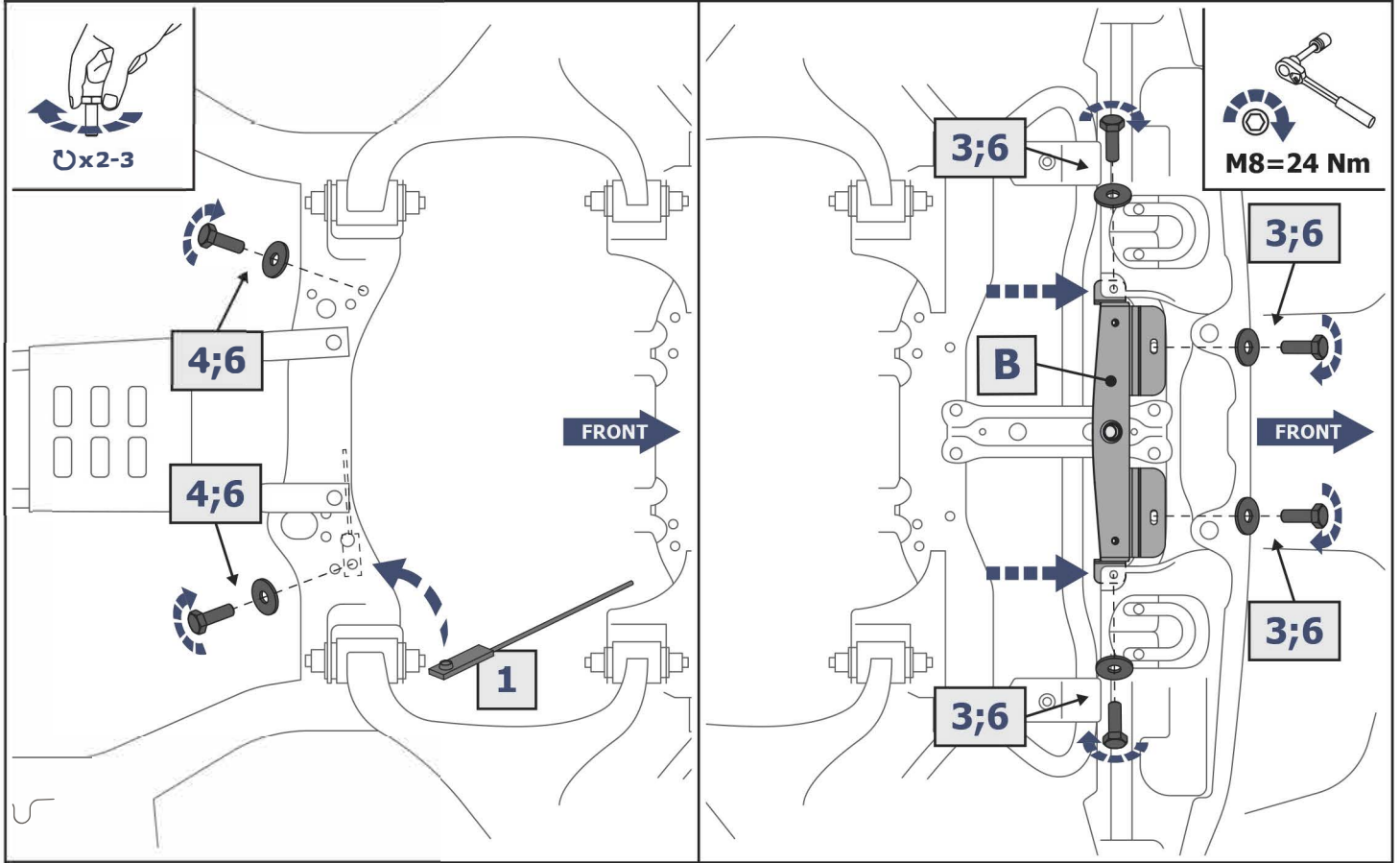

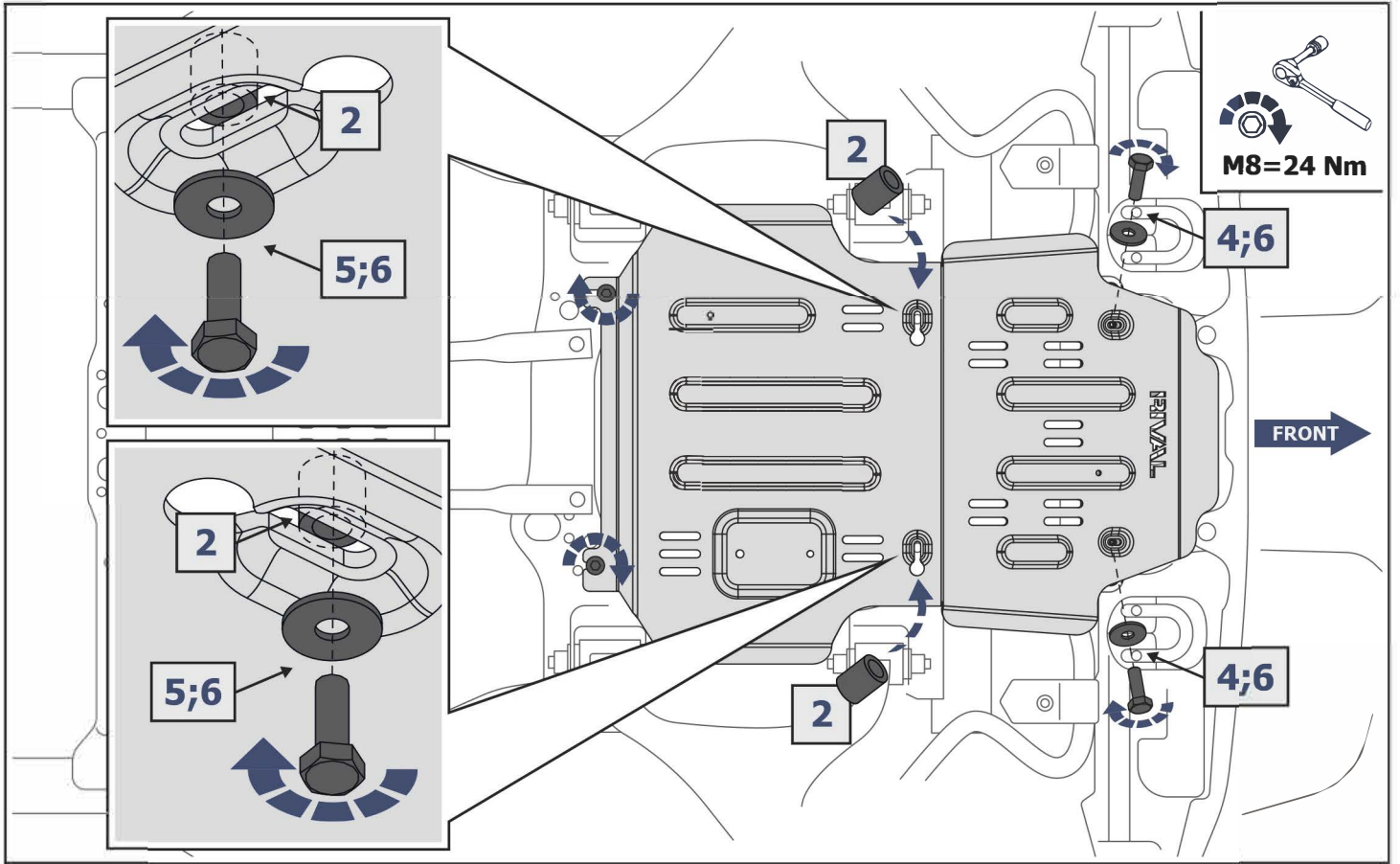

(EN) Mounting requirements:

Underbody Armour is developed individual for each car model.

Underbody Armour must be mounted according to installation manual by an authorized car dealer or by a special car repair stations.

Underbody Armour is to be installed to original points and holes of the power units of the car.

Installed properly Underbody Armour doesn't scrape another parts and assembly of the car.

(DE) Montageanleitung:

Der Unterfahr-/Unterbodenschutz wurde für jedes Fahrzeug individuell entwickelt. Der Unterfahr-/Unterbodenschutz ist gemäß Installationsanleitung des Herstellers bei einer autorisierten Werkstatt oder Autohändler zu montieren. Der Unterbodenschutz wird an den originalen Befestigungsbohrungen der Karosserie montiert. Bei Montage gemäß Herstellervorgaben werden keine anderen Karosserieteile beschädigt oder in Mitleidenschaft gezogen.

(EN) Working requirements:

Underbody Armour is designed for use and drive of the vehicle in conditions considere by the car manufacture.

While driving the carat speed, cases of collisions with large obstacles and objects need to be excluded.

In the case of a collision with an obstacle Underbody Armour and the vehicle must be inspected in a specialized car repair stations for damage of the components and assemblies and suitability for further use.

(DE) Herstellervorgaben:

Der Unterfahr-/Unterbodenschutz ist gemäß den Vorgaben des Fahrzeugherstellers zu verwenden. Das Befahren und Zusammenstoßen von/mit Hindernissen und großen Objekten ist zu unterlassen. Nach erfolgtem Zusammenstoß muss die Funktionsfähigkeit des Fahrzeuges und/oder entstandene Mängel von einer autorisierten Werkstatt überprüft werden.

EN Warranty:

Warranty period - 12 months.

DE Gewähr:

Die Dauer der Gewährleistung beträgt 12 Monate.

EN Warranty terms and conditions:

Underbody Armour is installed on the car, with good condition of the body and the assembly parts (the car, that was not involved in the accident).

Absence of mechanical damages of the Underbody Armour caused by a head-on crush;

Compliance with all installation requirements;

Absence of powder coating damages of the Underbody Armour;

The manufacturer is not liable for any damage caused to the vehicle, the life and health of people in the event of breach of the installation and using of Underbody Armour. The manufacturer has the right to change the design of Underbody Armour.

DE Gewährleistung:

Der Unterfahr-/Unterbodenschutz muss ohne Beschädigung und/oder Änderungen an Karosserie montiert worden sein. Es dürfen keine Schäden durch die Kollision mit Hindernissen/Gegenständen entstanden sein. Die Vorgaben der Montageanleitung müssen exakt eingehalten werden. Es dürfen keine Schäden/Kratzspuren an der Pulverbeschichtung vorhanden sein. Der Hersteller übernimmt keine Haftung für Fahrzeugschäden jedweder Art und gesundheitliche Gefährdungen durch fehlerhafte Montage und Nutzung des Unterbodenschutzes. Der Hersteller behält sich vor, Design und Konstruktionsänderungen des Unterbodenschutzes zu ändern.

**All products are certified
Alle Produkte sind zertifiziert**



EN GEARBOX PROTECTION INSTALLATION MANUAL

DE MONTAGEANLEITUNG FÜR GETRIEBE



**Underbody Armour for:
Toyota Land Cruiser 300 (2021-)**

2333.9552.1.6



EN Regular fasteners
DE Originale montageile



EN Regular fasteners
DE Originale montageile



EN Screw a several turns
DE Für wenigen Umdrehungen befestigen



EN Loosen bolts
DE Bolzen lockern

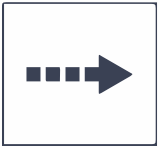

EN Movement Arrow
DE Bewegungsrichtung

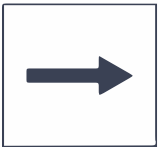



EN Location/Position Arrow
DE Anordnung/Positionsrichtung

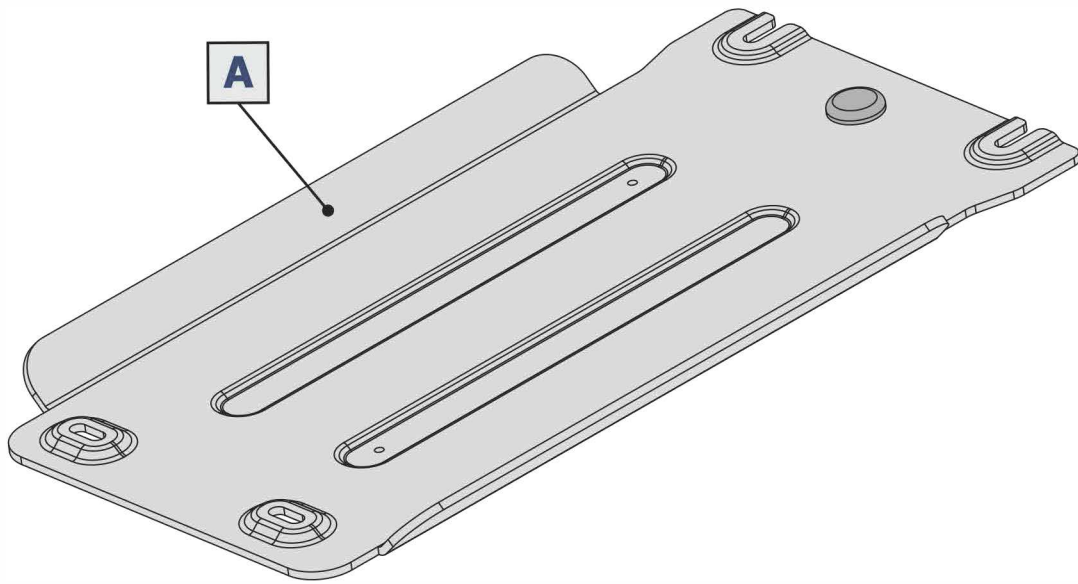
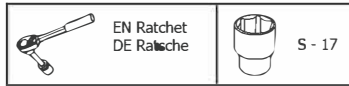

EN Screw Arrow
DE Drehungsrichtung

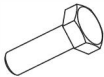

1		2		3	
	x2	M10x1.25x30	x2	Ø10	x2

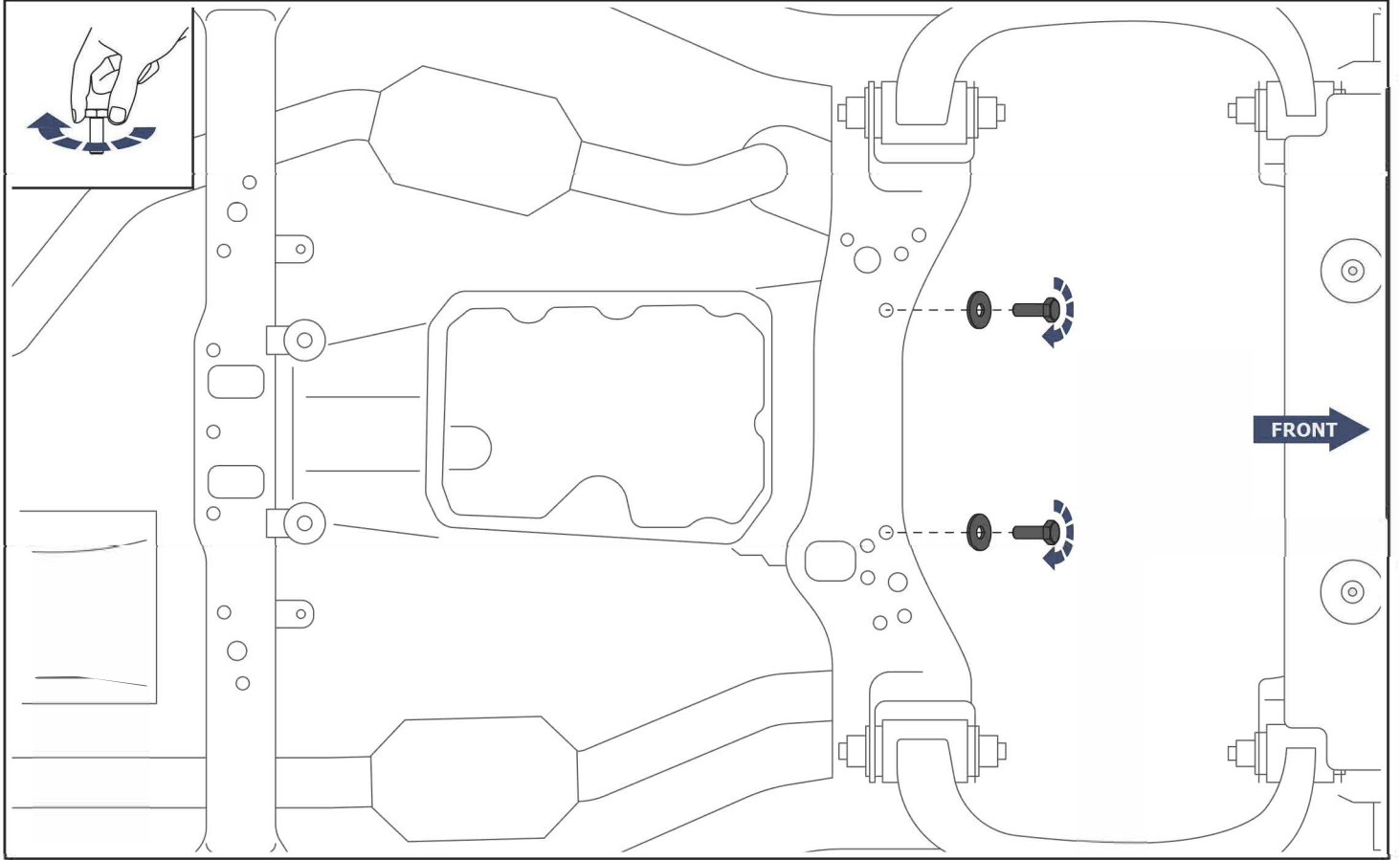
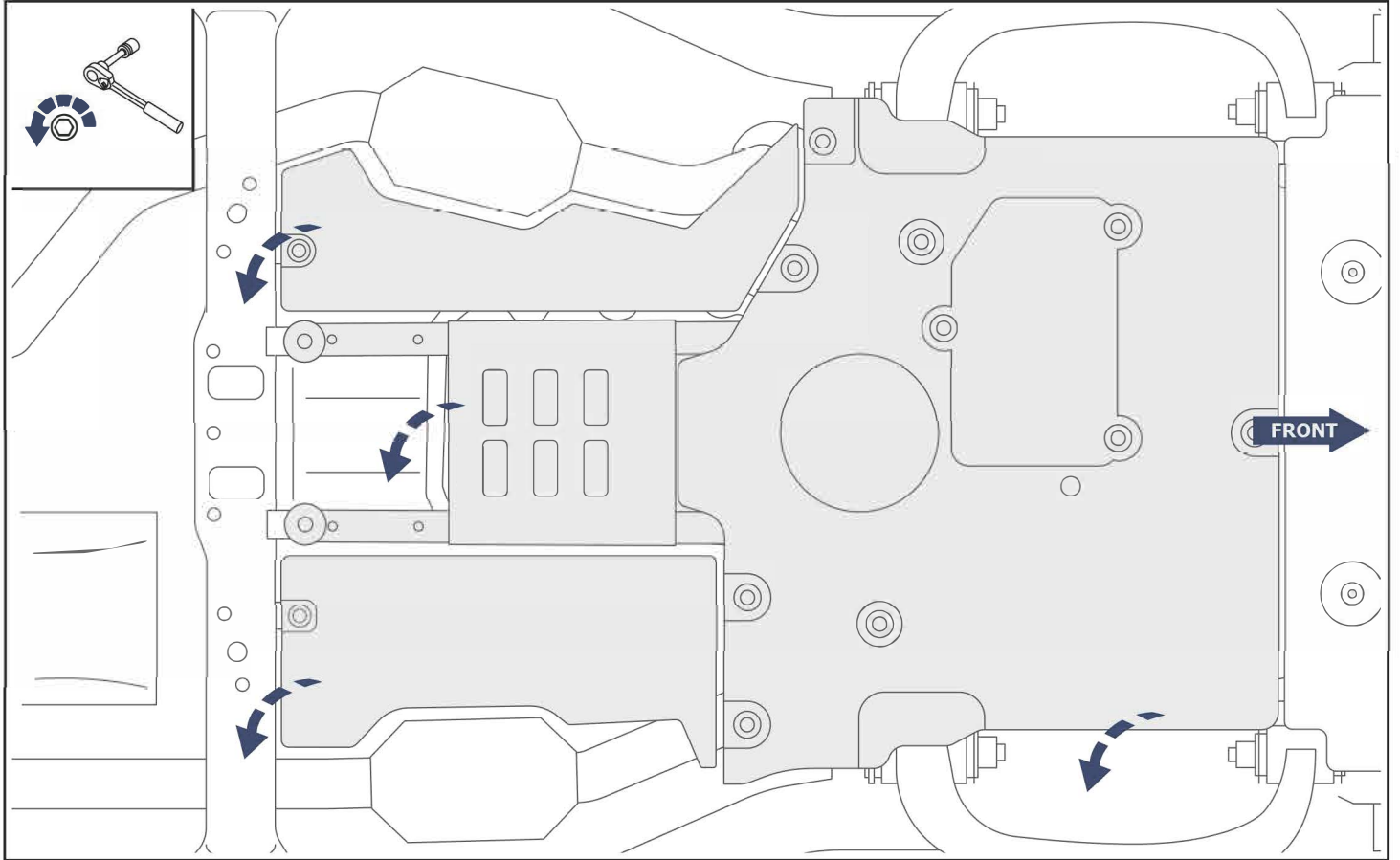

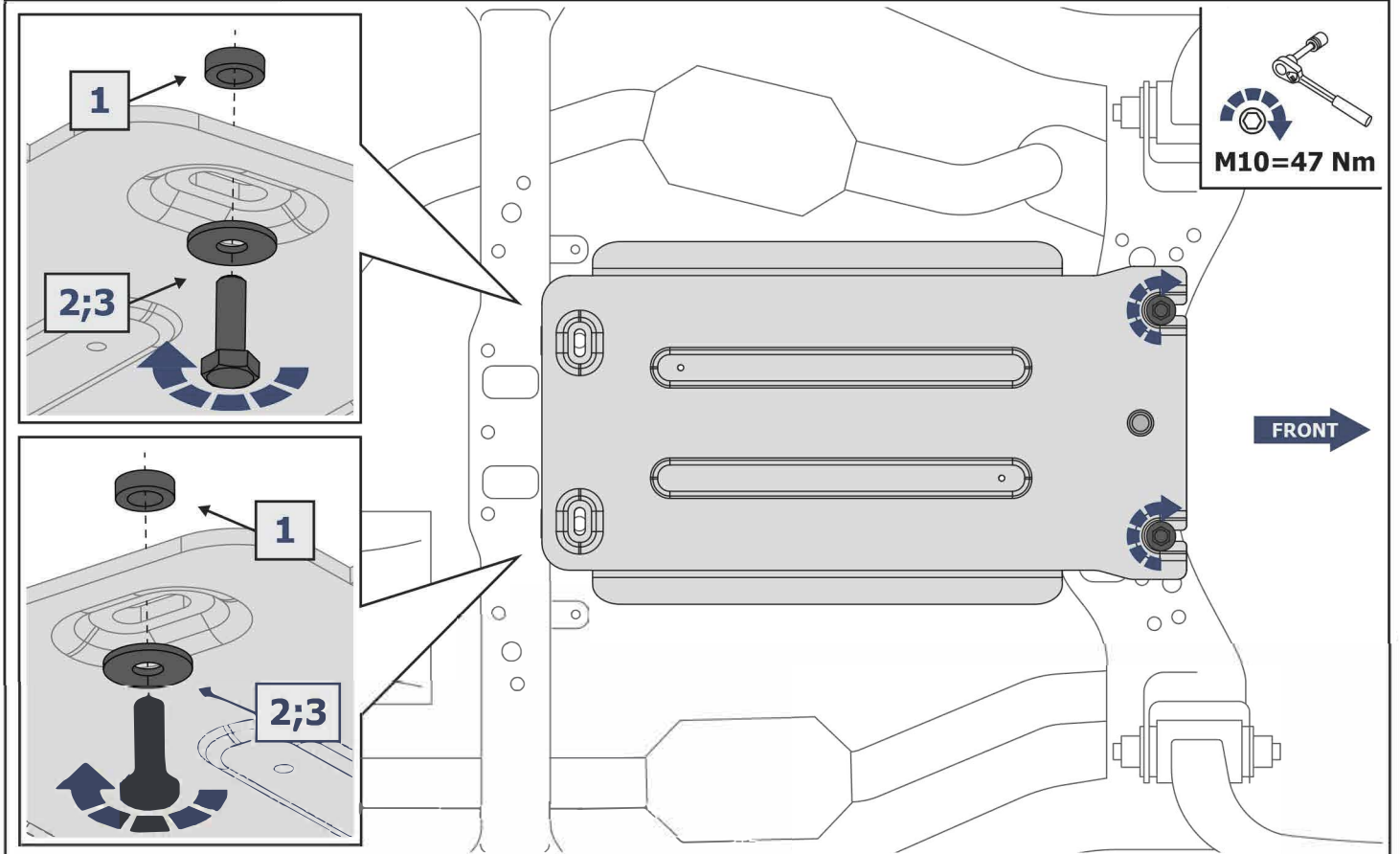
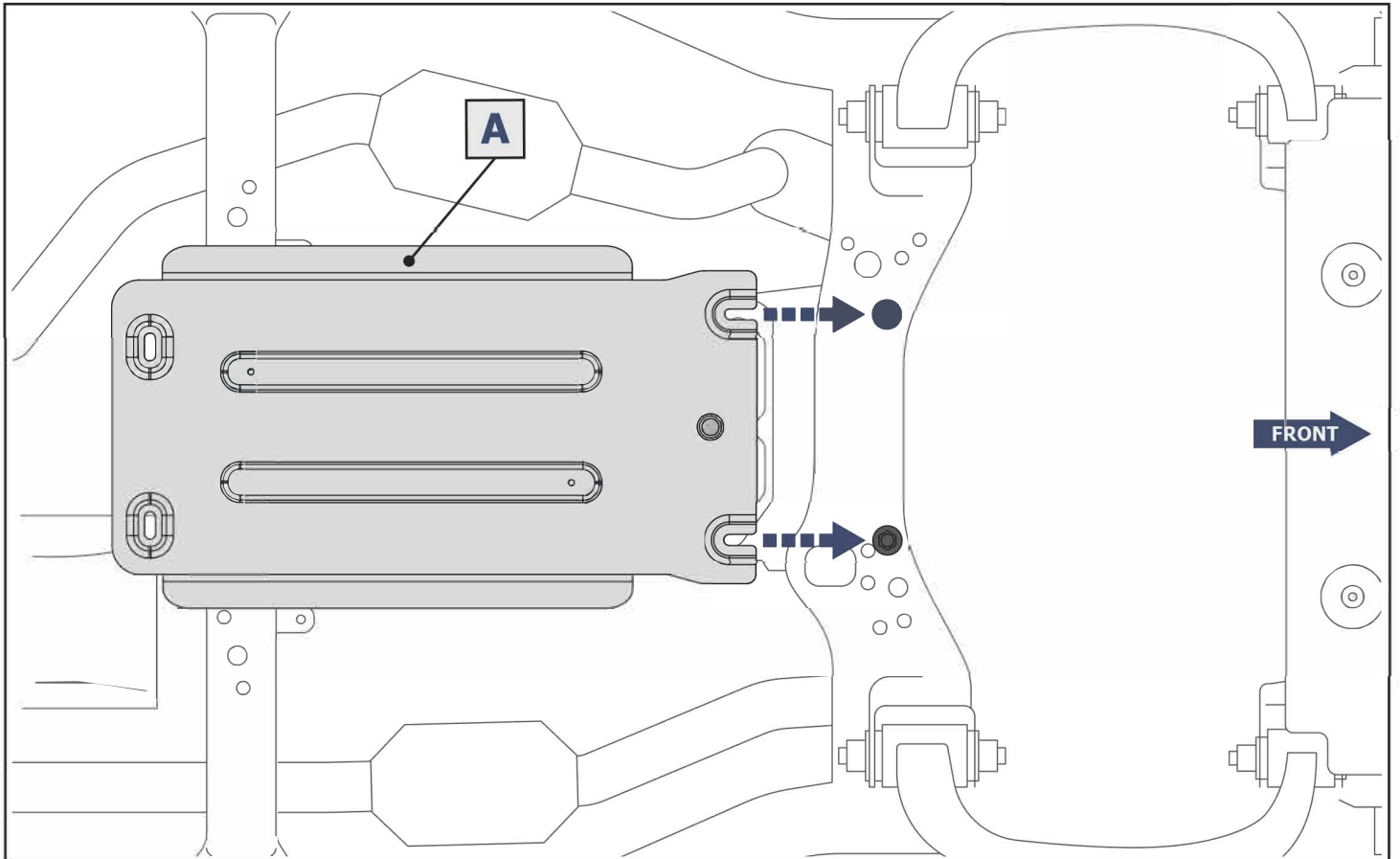

(EN) Mounting requirements:

Underbody Armour is developed individual for each car model.

Underbody Armour must be mounted according to installation manual by an authorized car dealer or by a special car repair stations.

Underbody Armour is to be installed to original points and holes of the power units of the car.

Installed properly Underbody Armour doesn't scrape another parts and assembly of the car.

(DE) Montageanleitung:

Der Unterfahr-/Unterbodenschutz wurde für jedes Fahrzeug individuell entwickelt. Der Unterfahr-/Unterbodenschutz ist gemäß Installationsanleitung des Herstellers bei einer autorisierten Werkstatt oder Autohändler zu montieren. Der Unterbodenschutz wird an den originalen Befestigungsbohrungen der Karosserie montiert. Bei Montage gemäß Herstellervorgaben werden keine anderen Karosserieteile beschädigt oder in Mitleidenschaft gezogen.

(EN) Working requirements:

Underbody Armour is designed for use and drive of the vehicle in conditions considere by the car manufacture.

While driving the carat speed, cases of collisions with large obstacles and objects need to be excluded.

In the case of a collision with an obstacle Underbody Armour and the vehicle must be inspected in a specialized car repair stations for damage of the components and assemblies and suitability for further use.

(DE) Herstellervorgaben:

Der Unterfahr-/Unterbodenschutz ist gemäß den Vorgaben des Fahrzeugherstellers zu verwenden. Das Befahren und Zusammenstoßen von/mit Hindernissen und großen Objekten ist zu unterlassen. Nach erfolgtem Zusammenstoß muss die Funktionsfähigkeit des Fahrzeuges und/oder entstandene Mängel von einer autorisierten Werkstatt überprüft werden.

EN Warranty:

Warranty period - 12 months.

DE Gewähr:

Die Dauer der Gewährleistung beträgt 12 Monate.

EN Warranty terms and conditions:

Underbody Armour is installed on the car, with good condition of the body and the assembly parts (the car, that was not involved in the accident).

Absence of mechanical damages of the Underbody Armour caused by a head-on crush;

Compliance with all installation requirements;

Absence of powder coating damages of the Underbody Armour;

The manufacturer is not liable for any damage caused to the vehicle, the life and health of people in the event of breach of the installation and using of Underbody Armour. The manufacturer has the right to change the design of Underbody Armour.

DE Gewährleistung:

Der Unterfahr-/Unterbodenschutz muss ohne Beschädigung und/oder Änderungen an Karosserie montiert worden sein. Es dürfen keine Schäden durch die Kollision mit Hindernissen/Gegenständen entstanden sein. Die Vorgaben der Montageanleitung müssen exakt eingehalten werden. Es dürfen keine Schäden/Kratzspuren an der Pulverbeschichtung vorhanden sein. Der Hersteller übernimmt keine Haftung für Fahrzeugschäden jedweder Art und gesundheitliche Gefährdungen durch fehlerhafte Montage und Nutzung des Unterbodenschutzes. Der Hersteller behält sich vor, Design und Konstruktionsänderungen des Unterbodenschutzes zu ändern.

**All products are certified
Alle Produkte sind zertifiziert**



EN **TRANSFER CASE PROTECTION INSTALLATION MANUAL**

DE **MONTAGEANLEITUNG FÜR VERTEILGETRIEBESCHUTZ**



**Underbody Armour for:
Toyota Land Cruiser 300 (2021-)**

2333.9553.1.6



EN Regular fasteners
DE Originale montageile



EN Regular fasteners
DE Originale montageile



EN Screw a several turns
DE Für wenigen Umdrehungen befestigen



EN Loosen bolts
DE Bolzen lockern

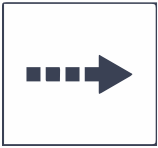

EN Movement Arrow
DE Bewegungsrichtung

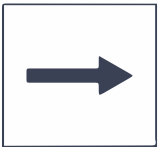





EN Location/Position Arrow
DE Anordnung/Positionsrichtung

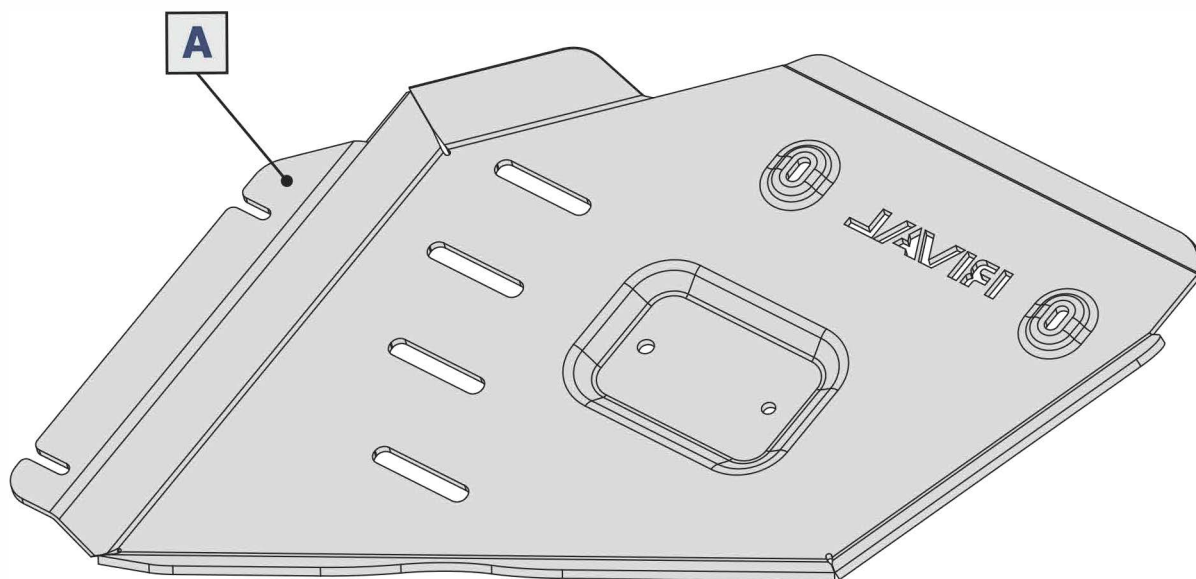
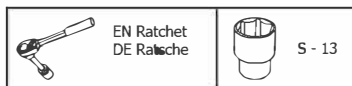

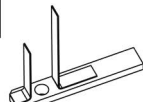
EN Screw Arrow
DE Drehungsrichtung



1  x2	2  x2	3  M8x25 x2	4  M8x40 x2	5  Ø8 x4
---	---	---	---	--

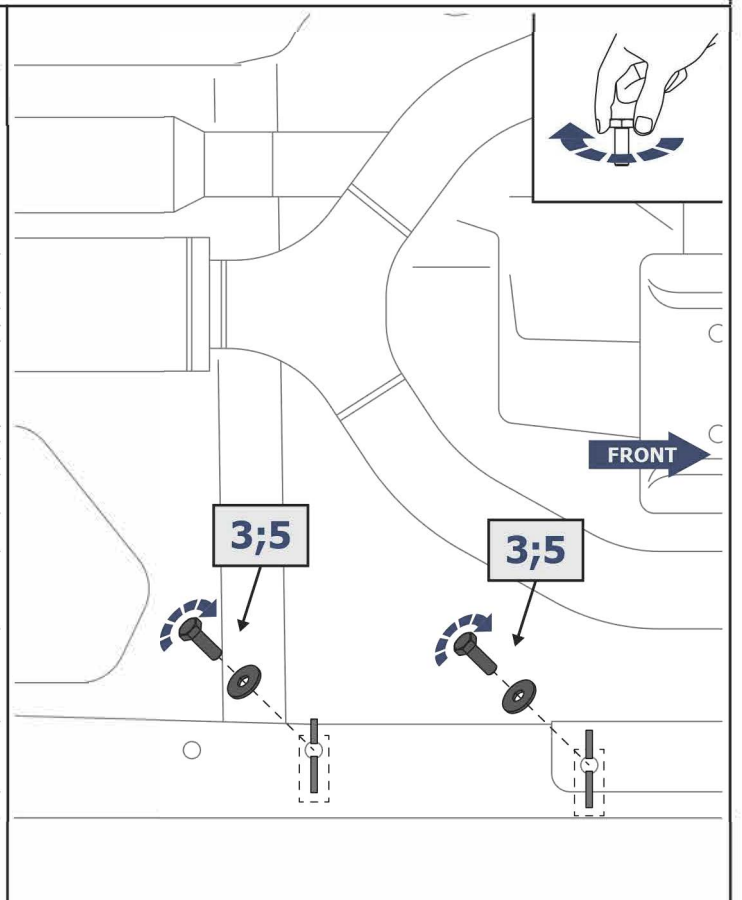
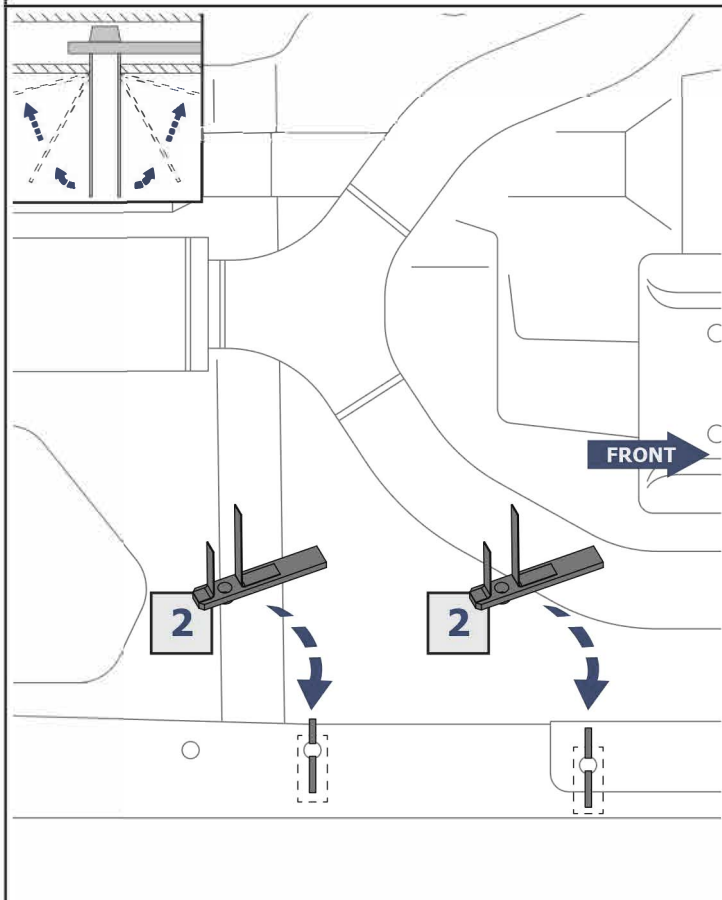
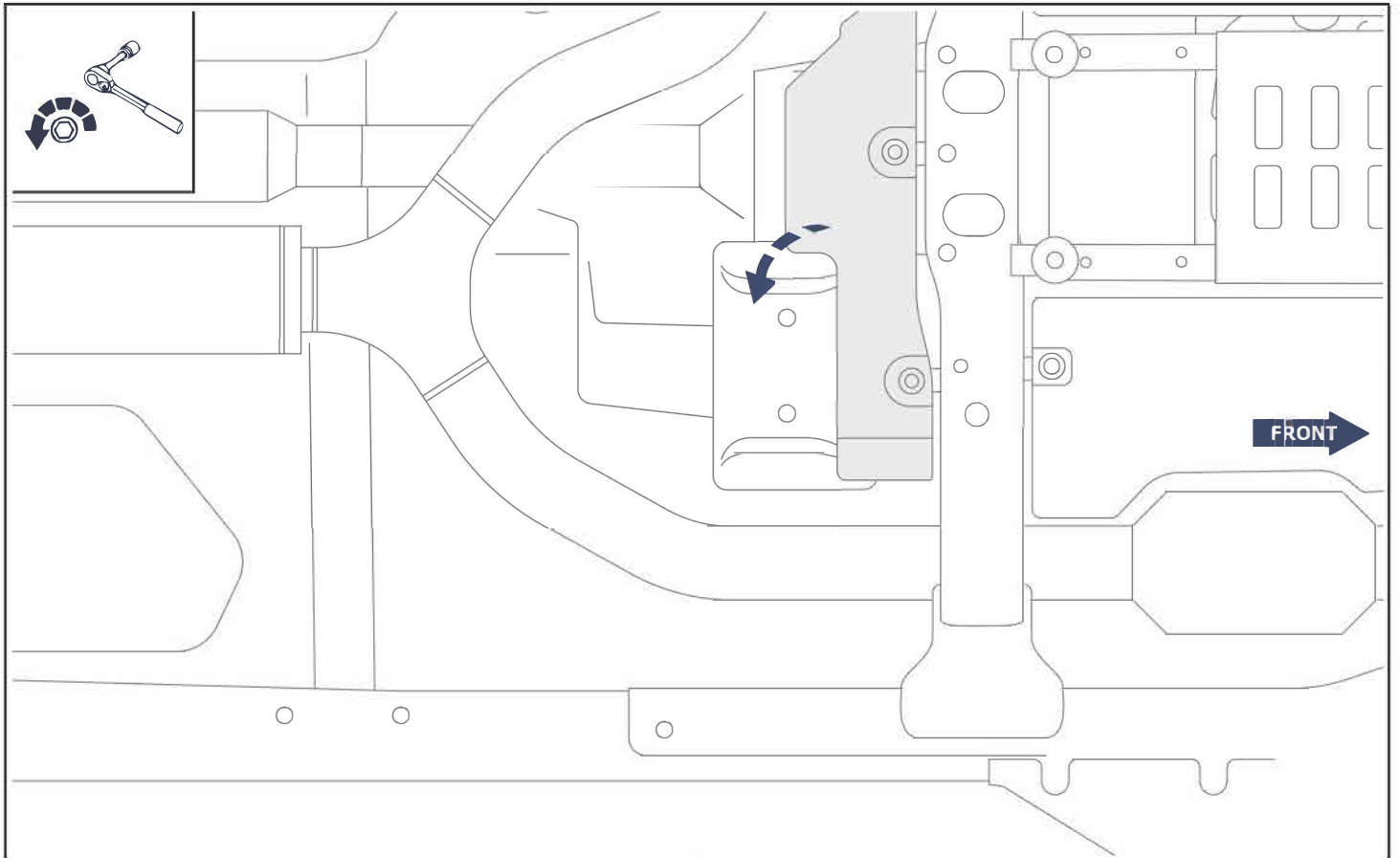

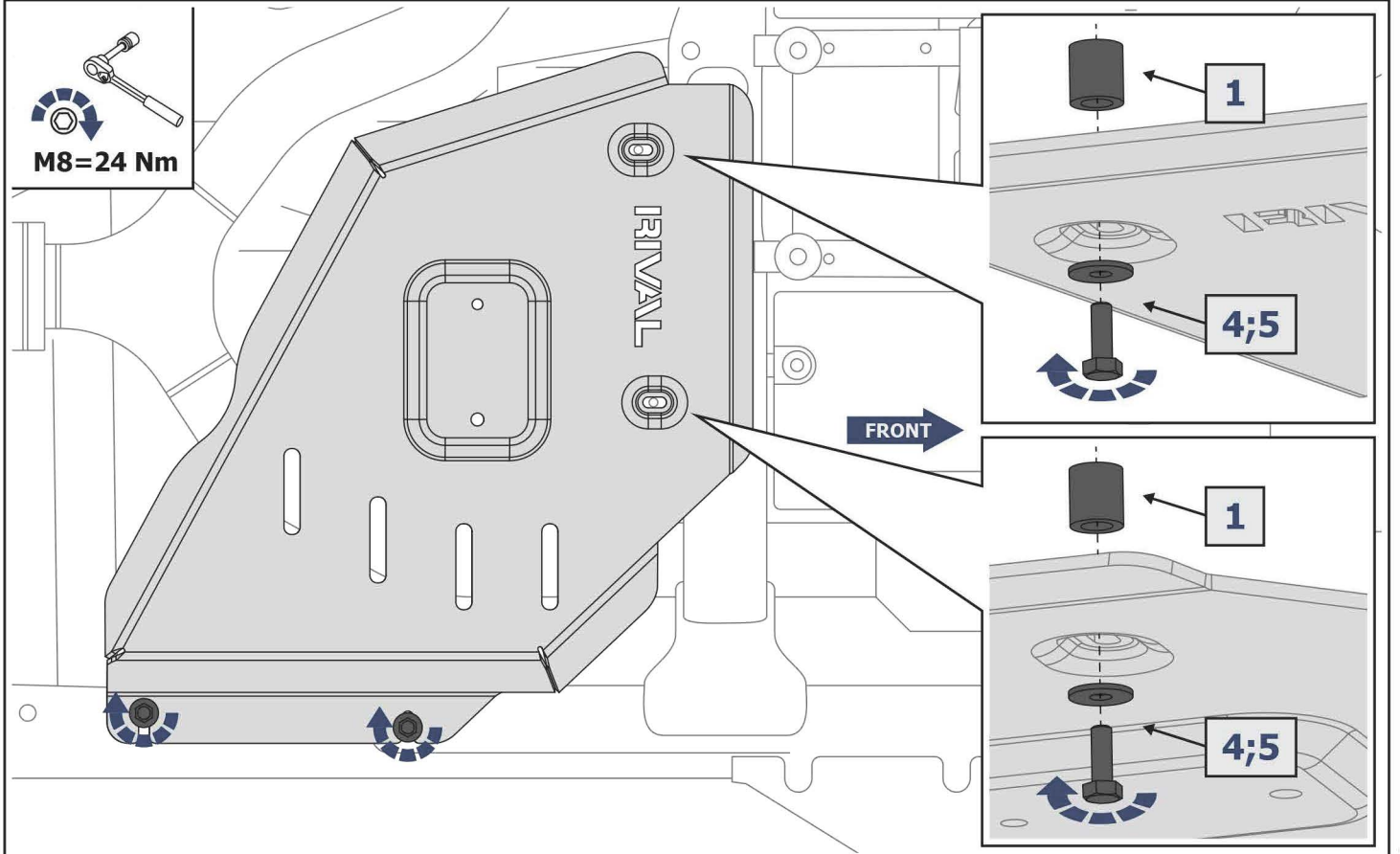
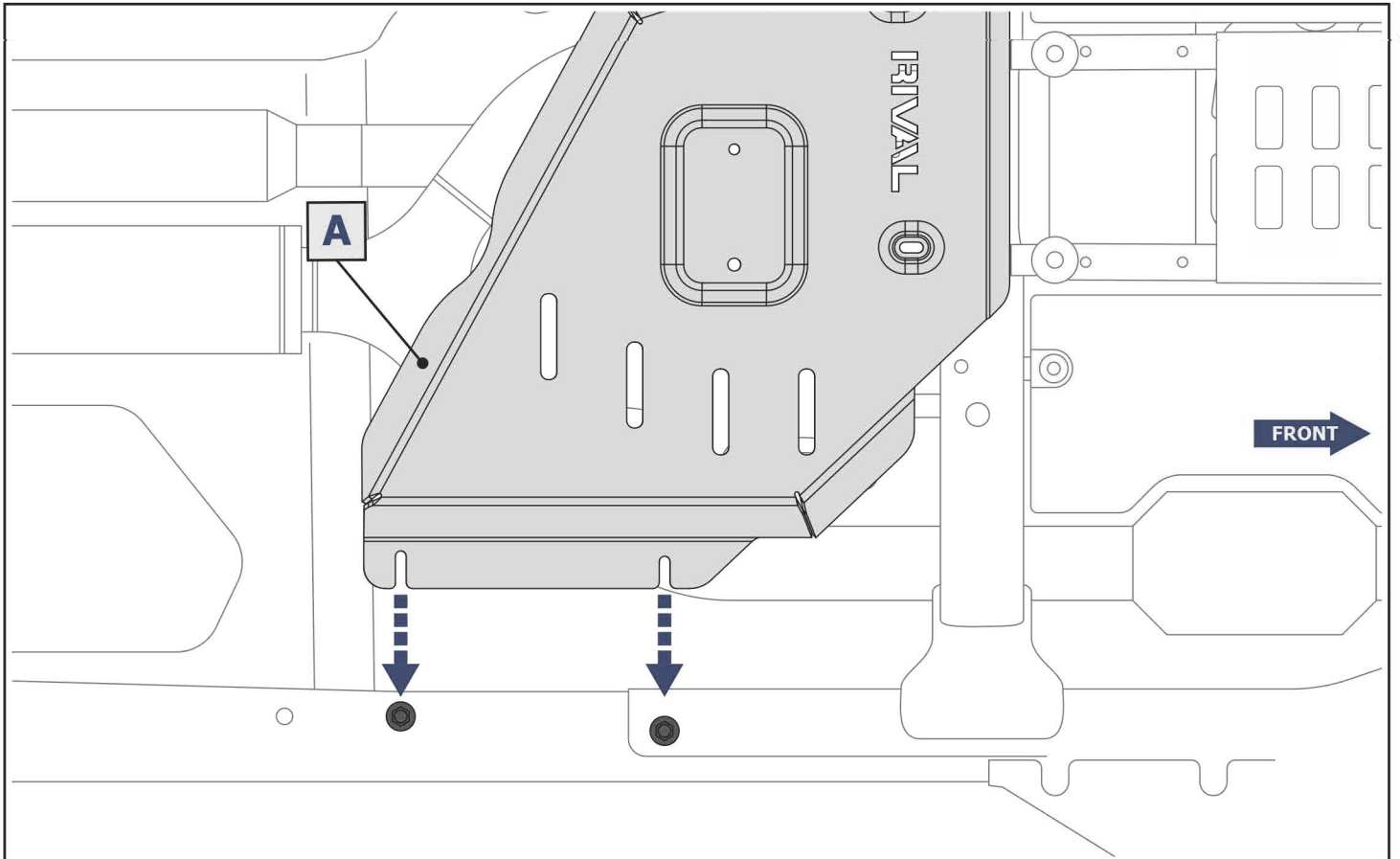

(EN) Mounting requirements:

Underbody Armour is developed individual for each car model.

Underbody Armour must be mounted according to installation manual by an authorized car dealer or by a special car repair stations.

Underbody Armour is to be installed to original points and holes of the power units of the car.

Installed properly Underbody Armour doesn't scrape another parts and assembly of the car.

(DE) Montageanleitung:

Der Unterfahr-/Unterbodenschutz wurde für jedes Fahrzeug individuell entwickelt. Der Unterfahr-/Unterbodenschutz ist gemäß Installationsanleitung des Herstellers bei einer autorisierten Werkstatt oder Autohändler zu montieren. Der Unterbodenschutz wird an den originalen Befestigungsbohrungen der Karosserie montiert. Bei Montage gemäß Herstellervorgaben werden keine anderen Karosserieteile beschädigt oder in Mitleidenschaft gezogen.

(EN) Working requirements:

Underbody Armour is designed for use and drive of the vehicle in conditions considere by the car manufacture.

While driving the carat speed, cases of collisions with large obstacles and objects need to be excluded.

In the case of a collision with an obstacle Underbody Armour and the vehicle must be inspected in a specialized car repair stations for damage of the components and assemblies and suitability for further use.

(DE) Herstellervorgaben:

Der Unterfahr-/Unterbodenschutz ist gemäß den Vorgaben des Fahrzeugherstellers zu verwenden. Das Befahren und Zusammenstoßen von/mit Hindernissen und großen Objekten ist zu unterlassen. Nach erfolgtem Zusammenstoß muss die Funktionsfähigkeit des Fahrzeuges und/oder entstandene Mängel von einer autorisierten Werkstatt überprüft werden.

EN Warranty:

Warranty period - 12 months.

DE Gewähr:

Die Dauer der Gewährleistung beträgt 12 Monate.

EN Warranty terms and conditions:

Underbody Armour is installed on the car, with good condition of the body and the assembly parts (the car, that was not involved in the accident).

Absence of mechanical damages of the Underbody Armour caused by a head-on crush;

Compliance with all installation requirements;

Absence of powder coating damages of the Underbody Armour;

The manufacturer is not liable for any damage caused to the vehicle, the life and health of people in the event of breach of the installation and using of Underbody Armour. The manufacturer has the right to change the design of Underbody Armour.

DE Gewährleistung:

Der Unterfahr-/Unterbodenschutz muss ohne Beschädigung und/oder Änderungen an Karosserie montiert worden sein. Es dürfen keine Schäden durch die Kollision mit Hindernissen/Gegenständen entstanden sein. Die Vorgaben der Montageanleitung müssen exakt eingehalten werden. Es dürfen keine Schäden/Kratzspuren an der Pulverbeschichtung vorhanden sein. Der Hersteller übernimmt keine Haftung für Fahrzeugschäden jedweder Art und gesundheitliche Gefährdungen durch fehlerhafte Montage und Nutzung des Unterbodenschutzes. Der Hersteller behält sich vor, Design und Konstruktionsänderungen des Unterbodenschutzes zu ändern.

**All products are certified
Alle Produkte sind zertifiziert**



ver.2

EN FUEL TANK PROTECTION INSTALLATION MANUAL

DE MONTAGEANLEITUNG FÜR TANKSCHUTZ



**Underbody Armour for:
Toyota Land Cruiser 300 (2021-)**

2333.9554.1.6

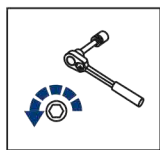

EN Regular fasteners
DE Originale montageile

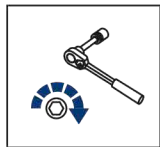

EN Regular fasteners
DE Originale montageile

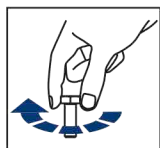

EN Screw a several turns
DE Für wenigen Umdrehungen befestigen



EN Loosen bolts
DE Bolzen lockern

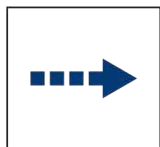

EN Movement Arrow
DE Bewegungsrichtung

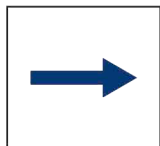





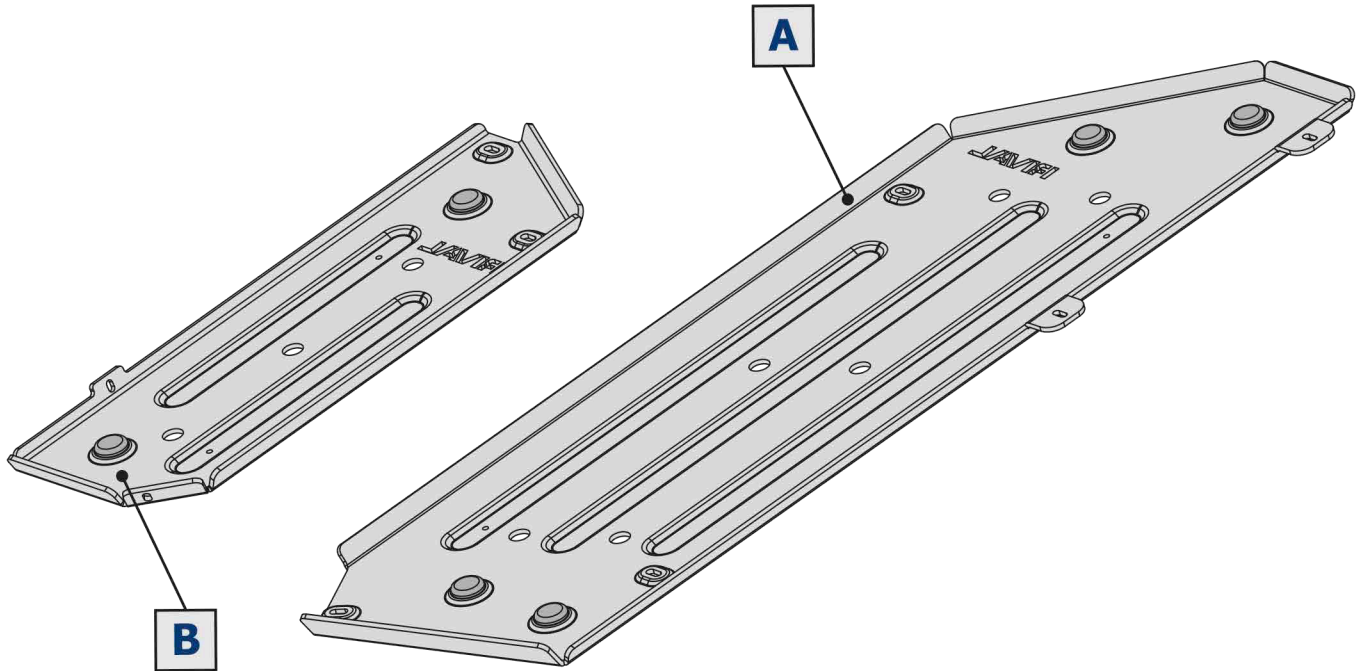

EN Location/Position Arrow
DE Anordnung/Positionsrichtung

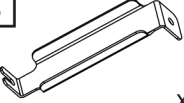

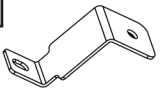
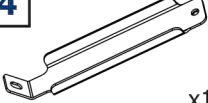
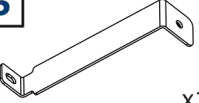
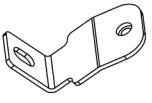
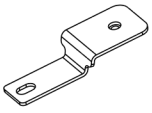
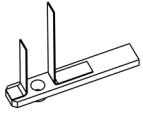
EN Screw Arrow
DE Drehungsrichtung



1  x1	2  x1	3  x1	4  x1	5  x1	6  x1
7  x1	8  x1	9  M8x16 x7	10  M8x30 x3	11  Ø8 x10	12  x2

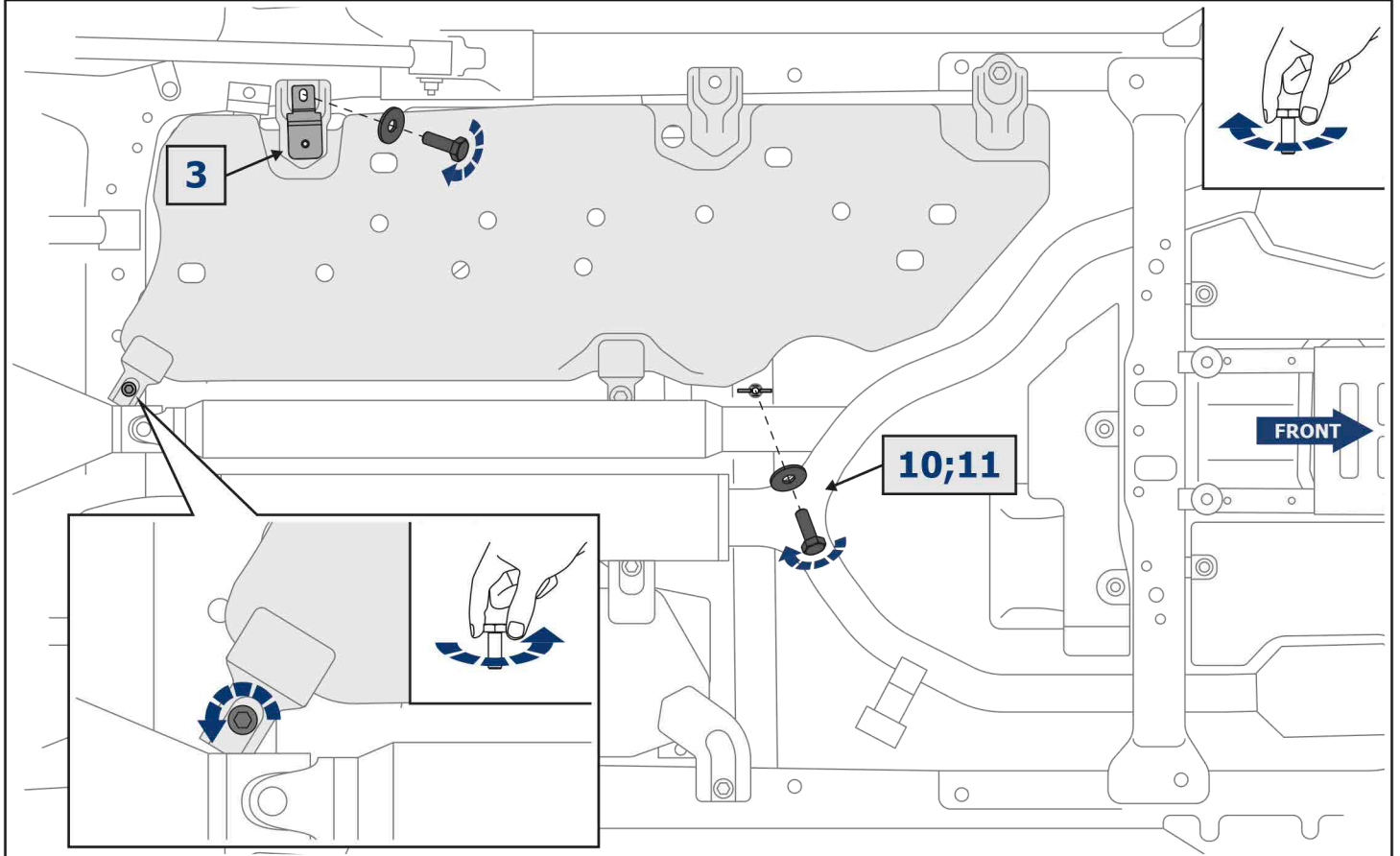
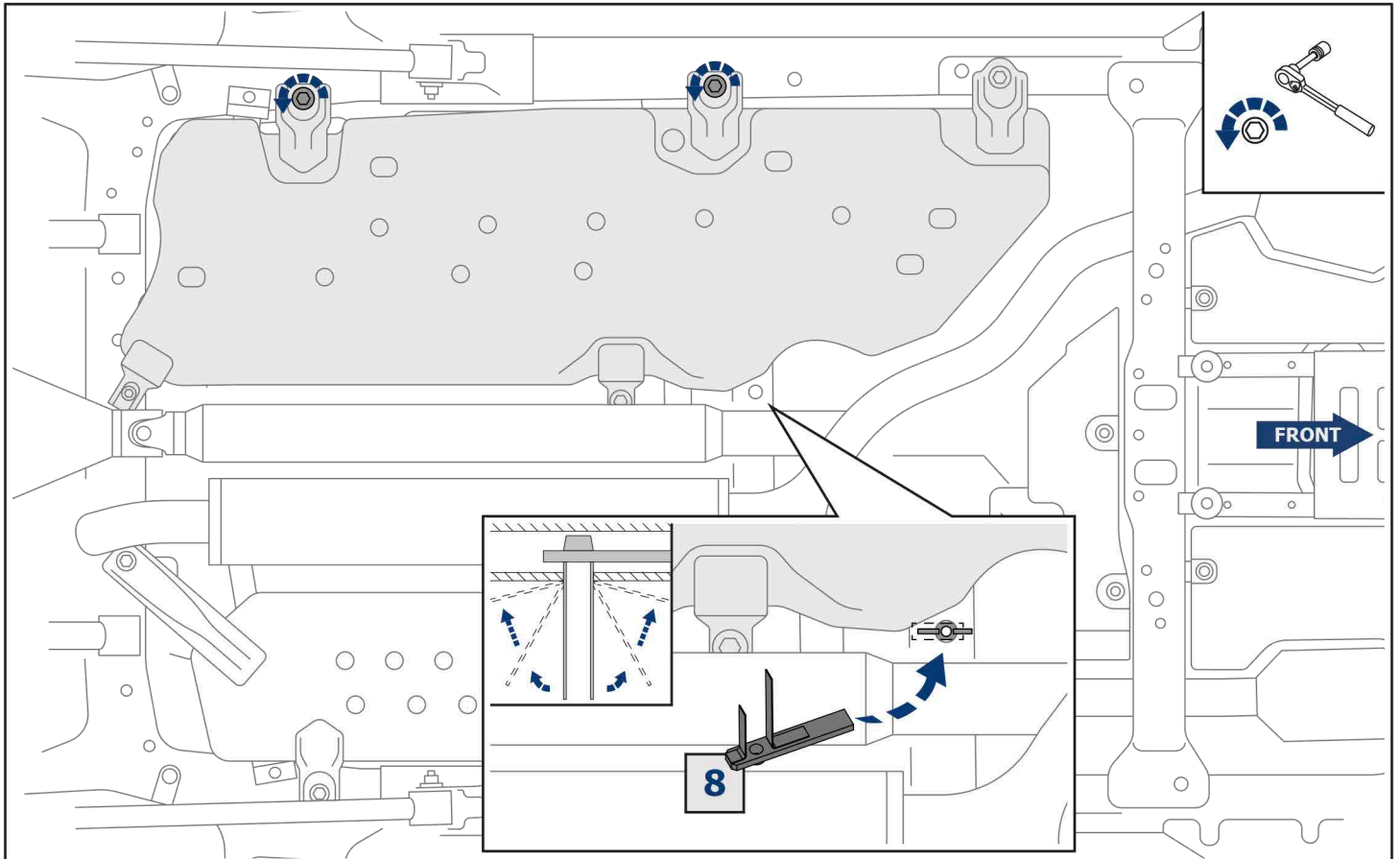

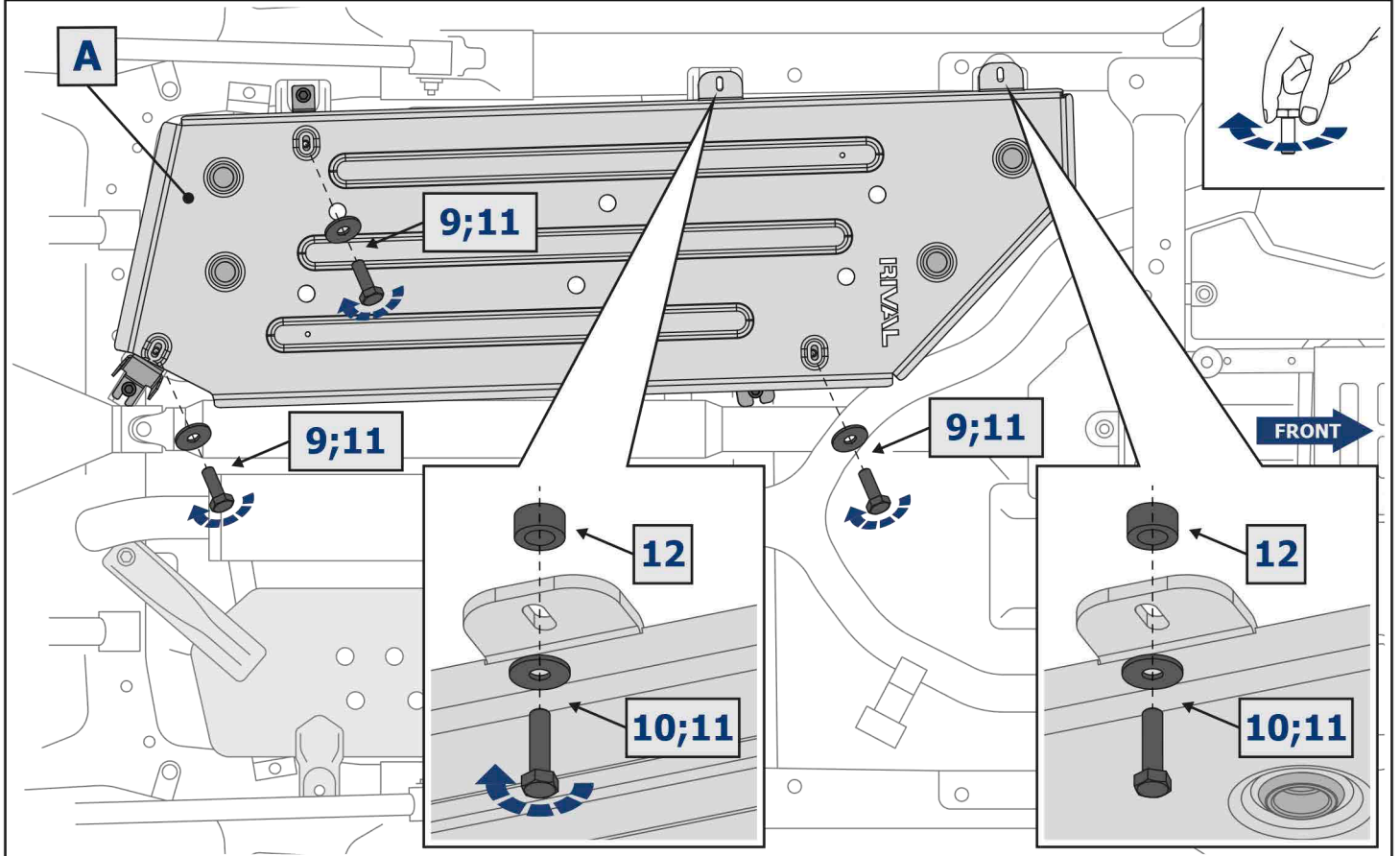
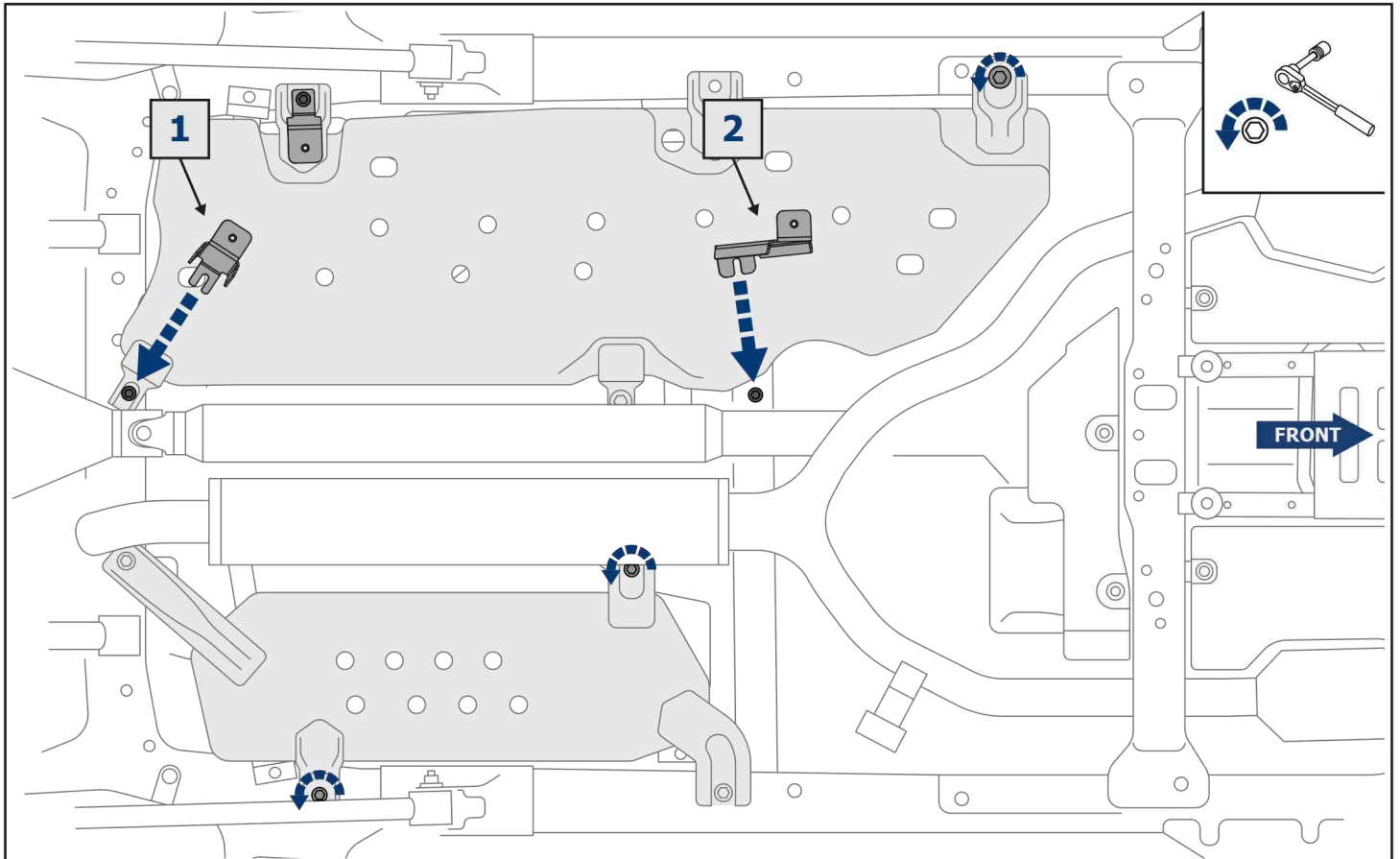

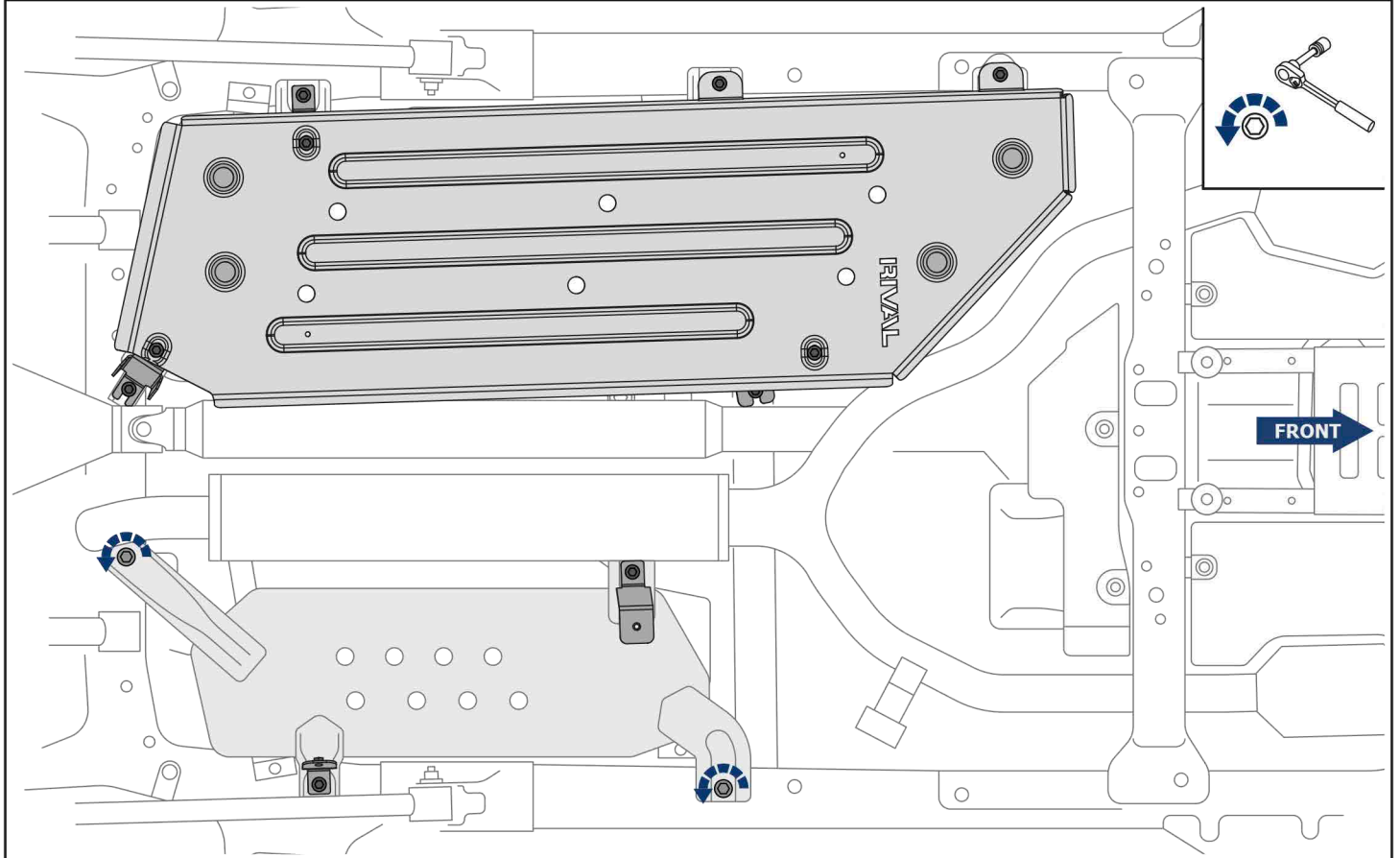
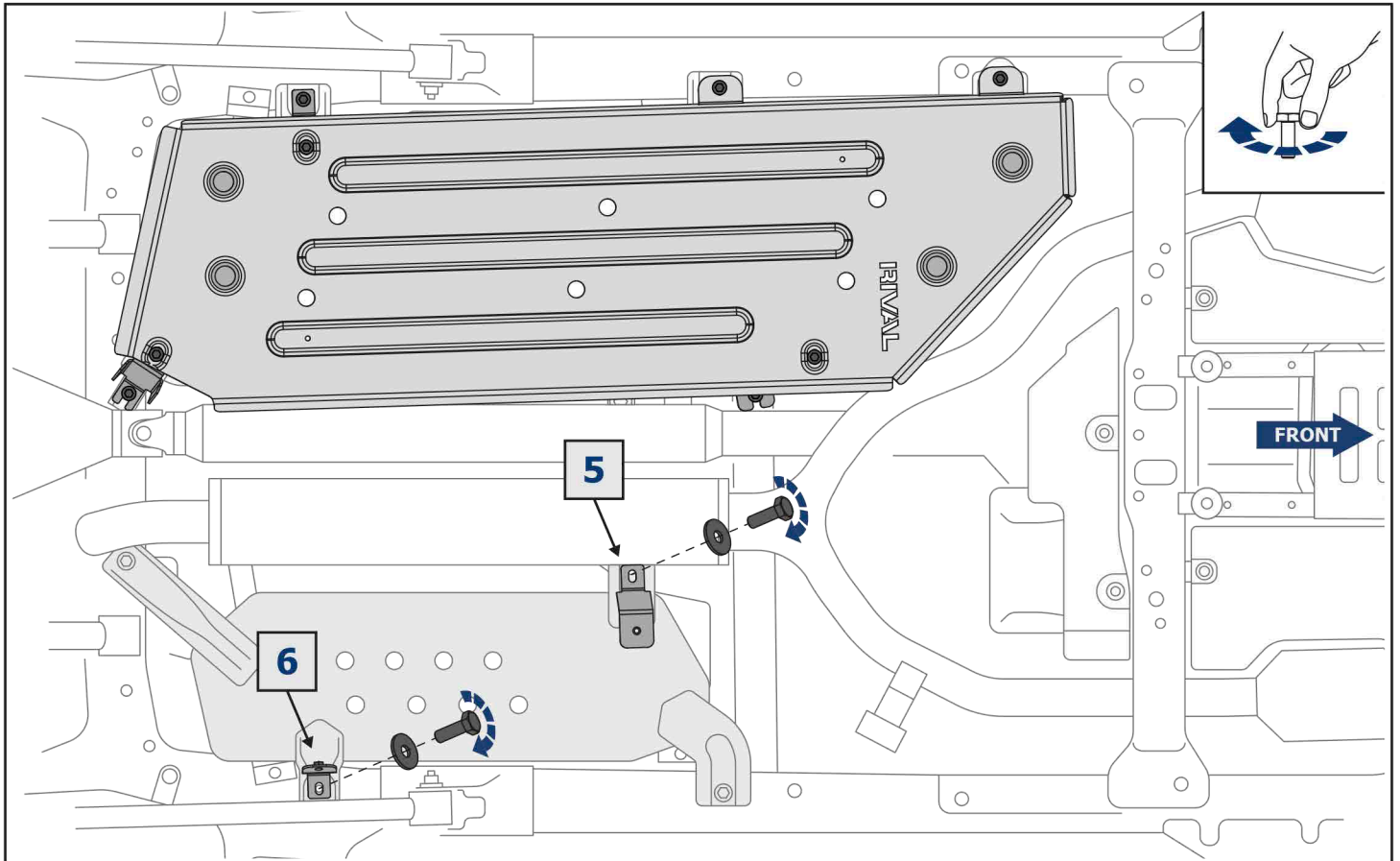

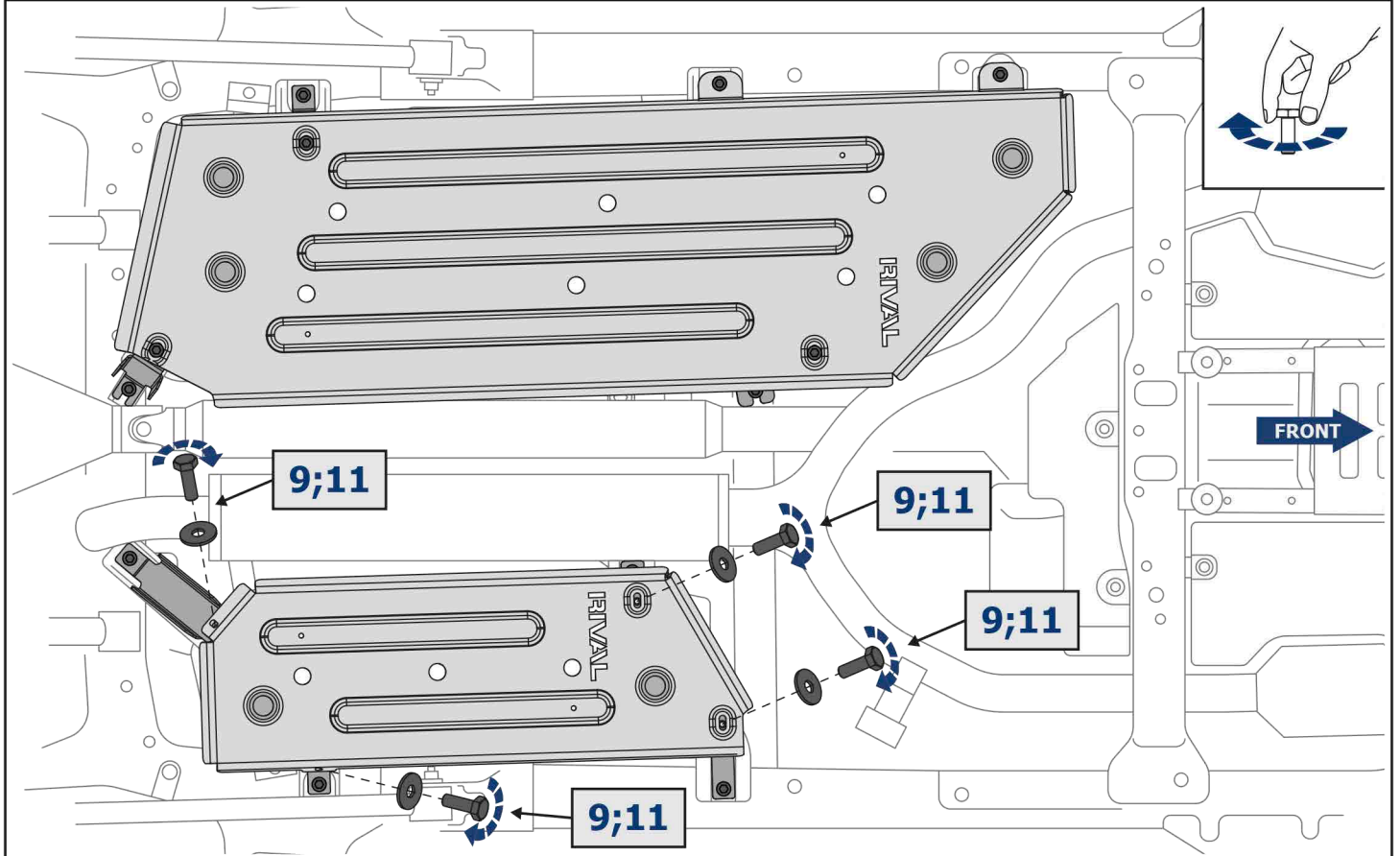
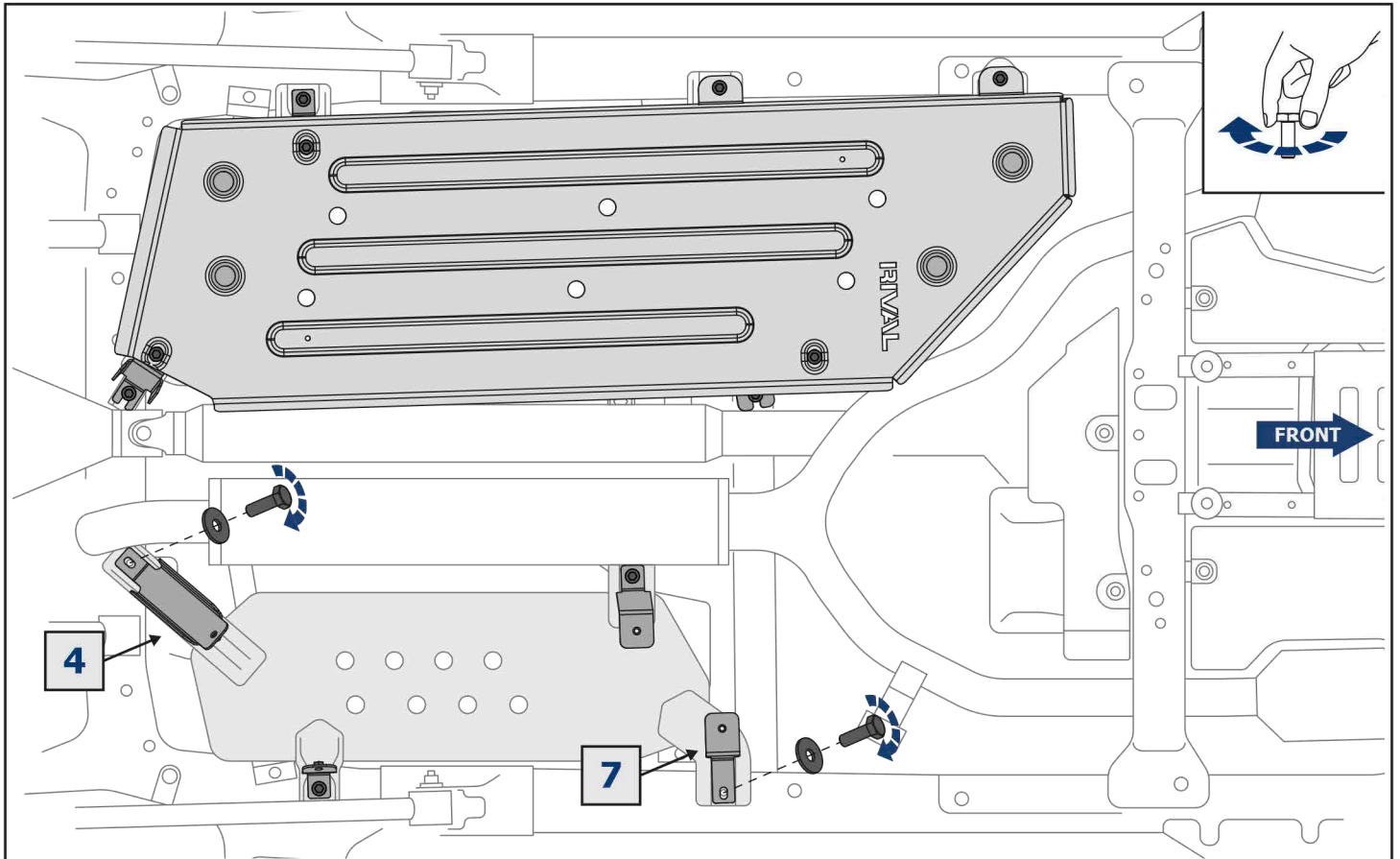

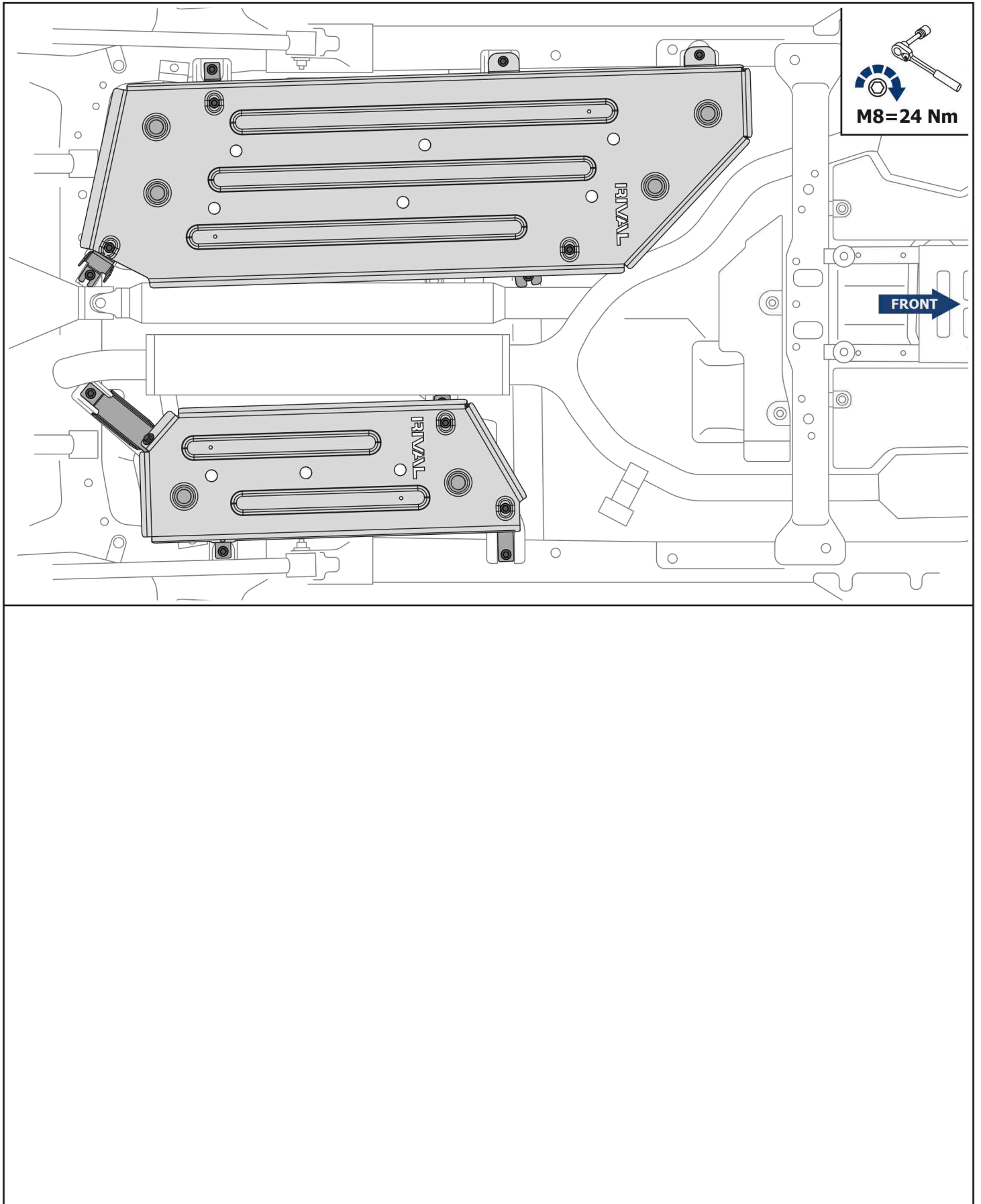

(EN) Mounting requirements:

Underbody Armour is developed individual for each car model.

Underbody Armour must be mounted according to installation manual by an authorized car dealer or by a special car repair stations.

Underbody Armour is to be installed to original points and holes of the power units of the car.

Installed properly Underbody Armour doesn't scrape another parts and assembly of the car.

(DE) Montageanleitung:

Der Unterfahr-/Unterbodenschutz wurde für jedes Fahrzeug individuell entwickelt. Der Unterfahr-/Unterbodenschutz ist gemäß Installationsanleitung des Herstellers bei einer autorisierten Werkstatt oder Autohändler zu montieren. Der Unterbodenschutz wird an den originalen Befestigungsbohrungen der Karosserie montiert. Bei Montage gemäß Herstellervorgaben werden keine anderen Karosserieteile beschädigt oder in Mitleidenschaft gezogen.

(EN) Working requirements:

Underbody Armour is designed for use and drive of the vehicle in conditions considere by the car manufacture.

While driving the carat speed, cases of collisions with large obstacles and objects need to be excluded.

In the case of a collision with an obstacle Underbody Armour and the vehicle must be inspected in a specialized car repair stations for damage of the components and assemblies and suitability for further use.

(DE) Herstellervorgaben:

Der Unterfahr-/Unterbodenschutz ist gemäß den Vorgaben des Fahrzeugherstellers zu verwenden. Das Befahren und Zusammenstoßen von/mit Hindernissen und großen Objekten ist zu unterlassen. Nach erfolgtem Zusammenstoß muss die Funktionsfähigkeit des Fahrzeuges und/oder entstandene Mängel von einer autorisierten Werkstatt überprüft werden.

EN Warranty:

Warranty period - 12 months.

DE Gewähr:

Die Dauer der Gewährleistung beträgt 12 Monate.

EN Warranty terms and conditions:

Underbody Armour is installed on the car, with good condition of the body and the assembly parts (the car, that was not involved in the accident).

Absence of mechanical damages of the Underbody Armour caused by a head-on crush;

Compliance with all installation requirements;

Absence of powder coating damages of the Underbody Armour;

The manufacturer is not liable for any damage caused to the vehicle, the life and health of people in the event of breach of the installation and using of Underbody Armour. The manufacturer has the right to change the design of Underbody Armour.

DE Gewährleistung:

Der Unterfahr-/Unterbodenschutz muss ohne Beschädigung und/oder Änderungen an Karosserie montiert worden sein. Es dürfen keine Schäden durch die Kollision mit Hindernissen/Gegenständen entstanden sein. Die Vorgaben der Montageanleitung müssen exakt eingehalten werden. Es dürfen keine Schäden/Kratzspuren an der Pulverbeschichtung vorhanden sein. Der Hersteller übernimmt keine Haftung für Fahrzeugschäden jedweder Art und gesundheitliche Gefährdungen durch fehlerhafte Montage und Nutzung des Unterbodenschutzes. Der Hersteller behält sich vor, Design und Konstruktionsänderungen des Unterbodenschutzes zu ändern.

All products are certified
Alle Produkte sind zertifiziert

