

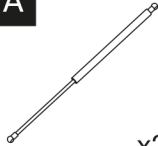

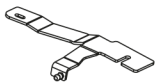

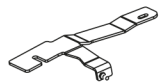
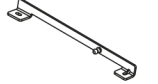

Volkswagen Amarok

HOOD GAS STRUTS KIT
Installation Instructions

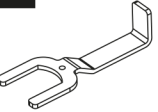

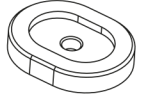
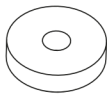
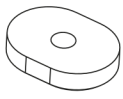
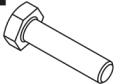
Model year:	2010-04.2017
Part No.:	2A.ST.5809.1 (V1)
Compatibility:	V 2.0
Weight:	⚖ 1 kg
Installation time:	🕒 30 min

A  x2	B1  x1	B2  x1	C1  x1	C2  x1
D  x1	E  x1	F  x1	G  x1	H  x1
I  M8x30 x2	J  ø8 x2	Installation Instructions 		

Required Tools

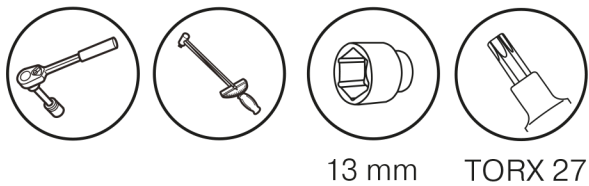

Attention!

Before installation of gas struts, open the hood and check that there is no additional equipment installed in engine bay which can block installation.

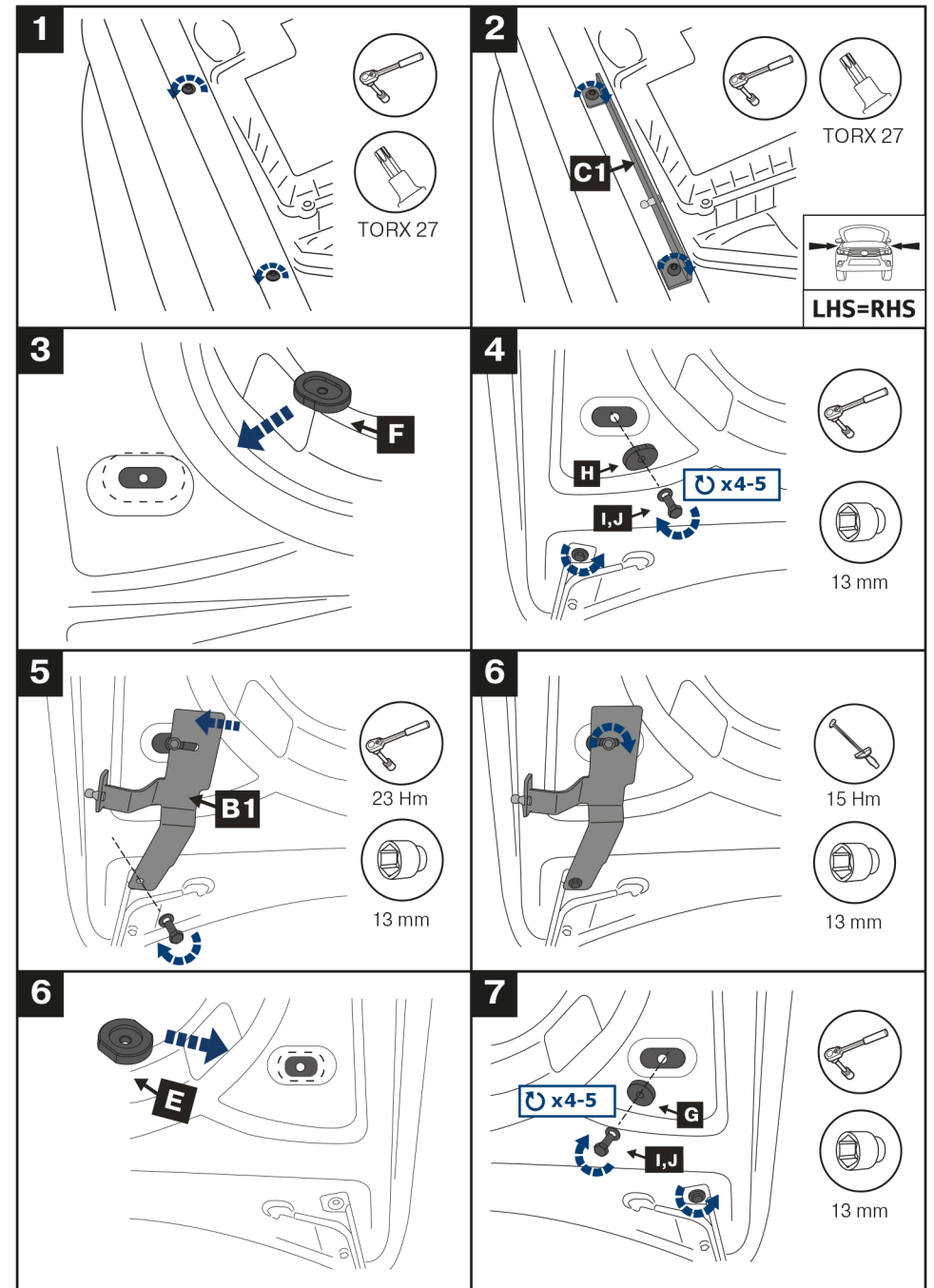

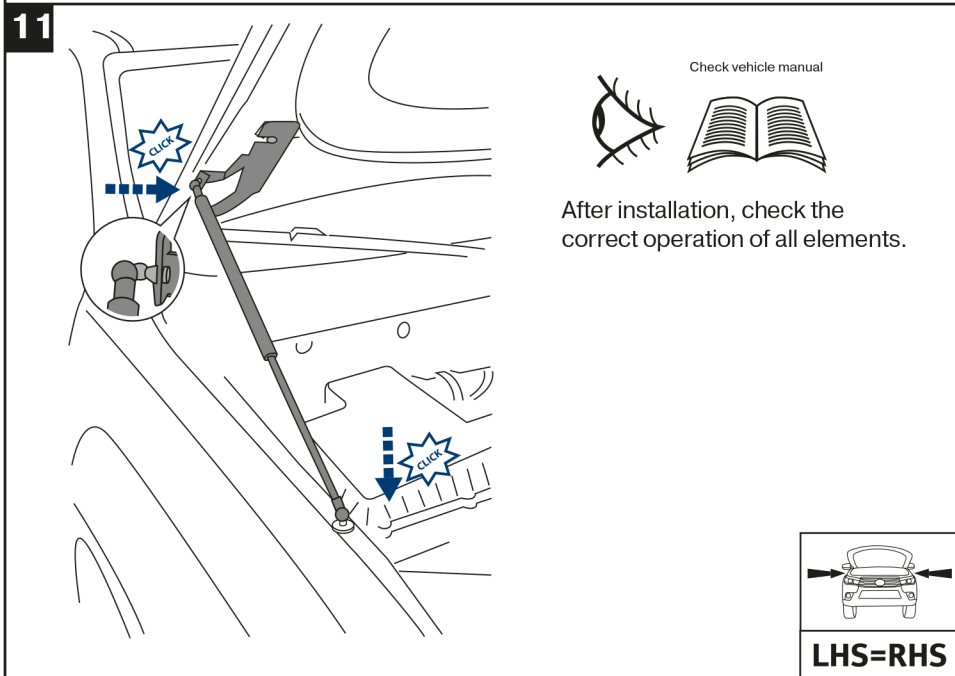
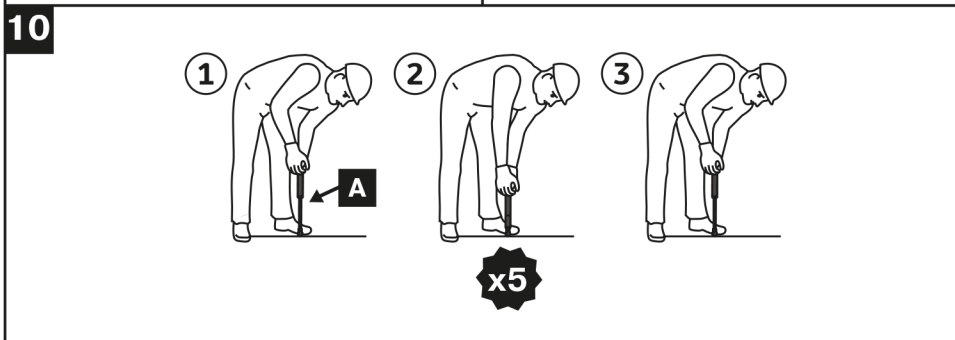
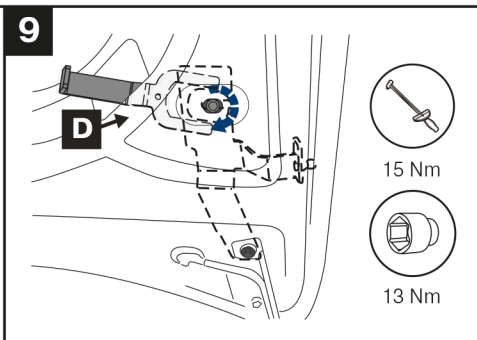
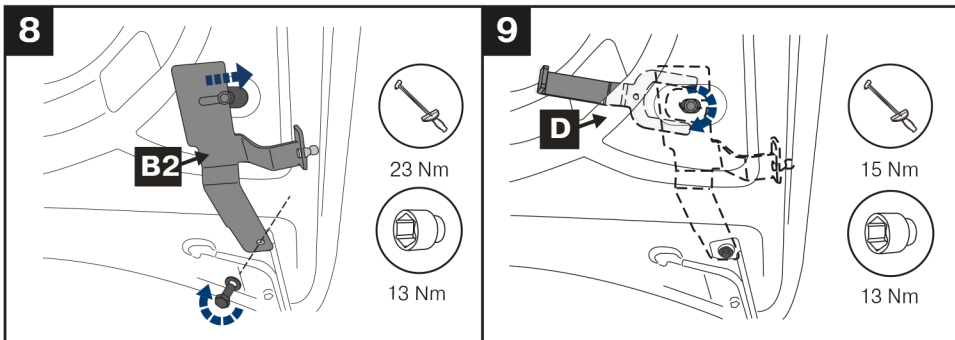

Volkswagen Amarok

HOOD GAS STRUTS KIT
Installation Instructions



Model year:	05.2017-
Part No.:	2A.ST.5809.1 (V2)
Compatibility:	V=3,0 (2016-); V=2,0 (05.2017-)
Weight:	1 kg
Installation time:	30 min

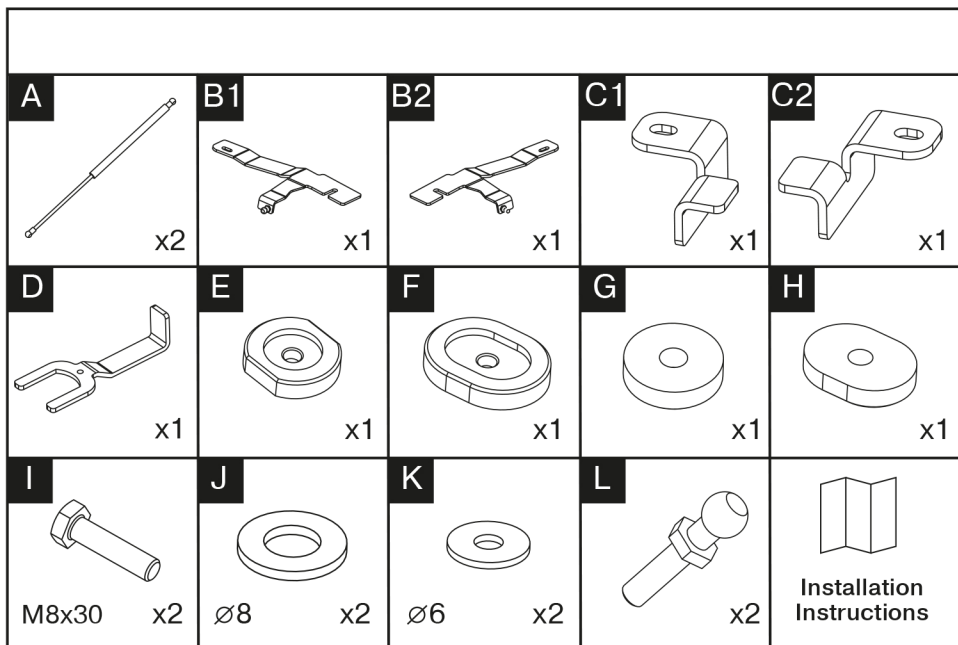

Required Tools

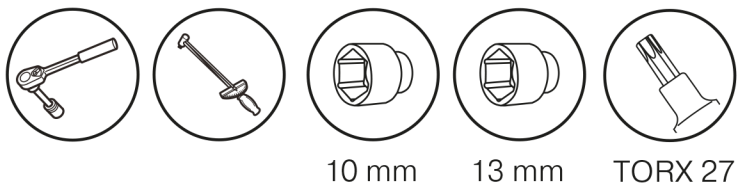

⚠ Attention!

Before installation of gas struts, open the hood and check that there is no additional equipment installed in engine bay which can block installation.

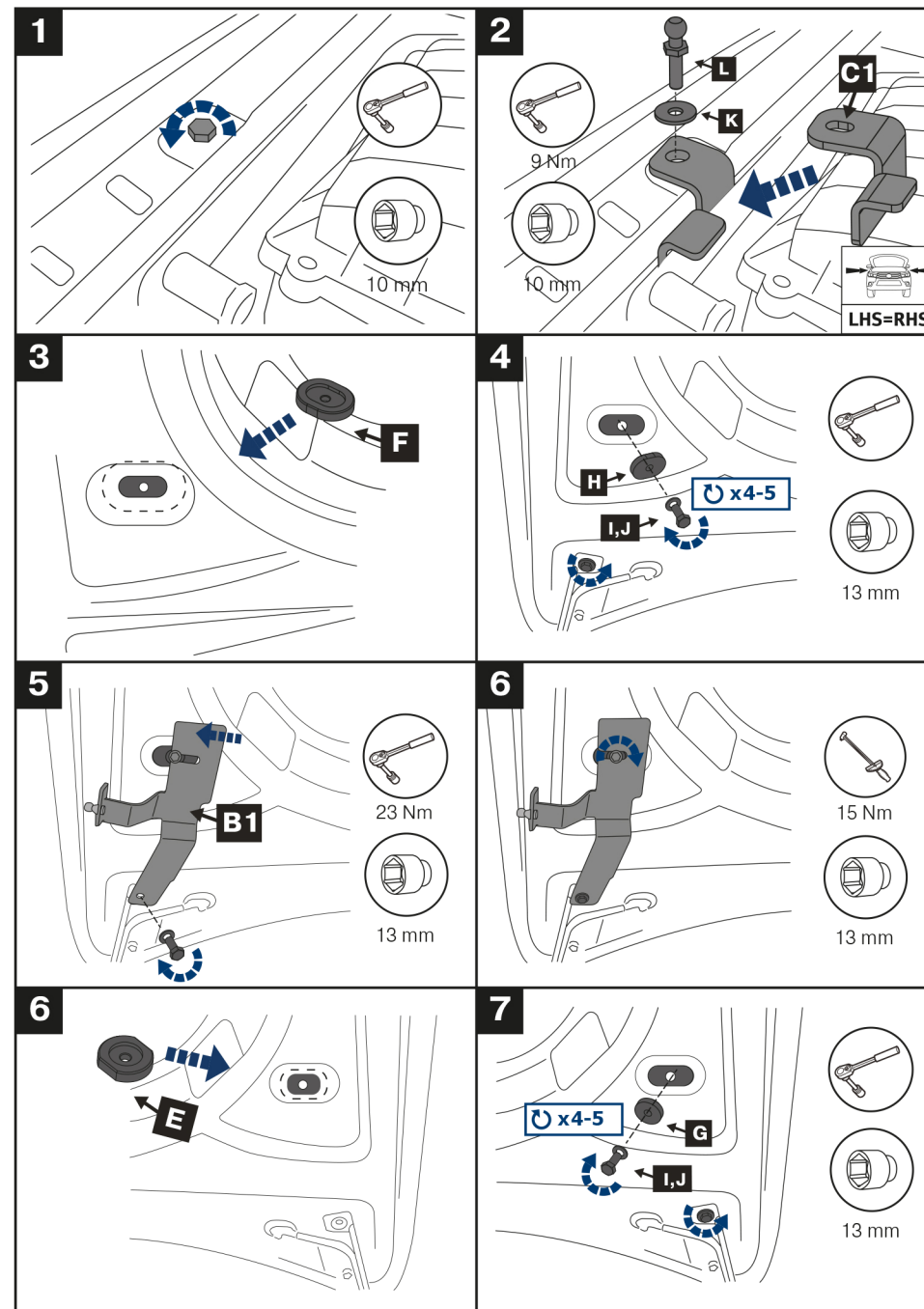

Information booklet

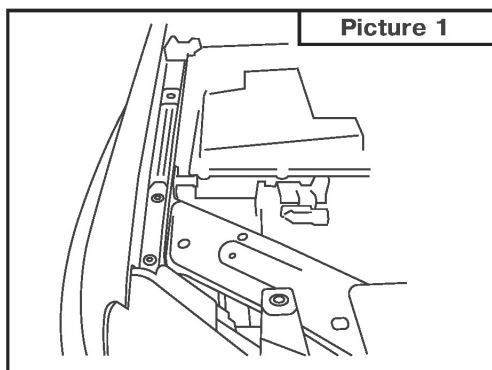

If your car has the same construction as in **picture 1** use Installation instruction **V1** and package **V1** + package without label.

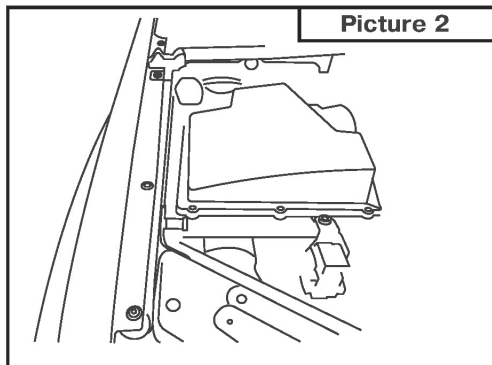

If your car has the same construction as in **picture 2** use Installation instruction **V2** and package **V2** + package without label.